

Wiringkit

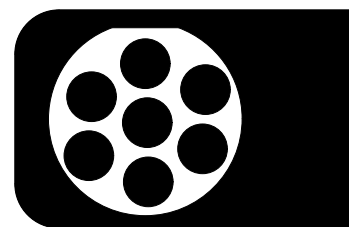

D	Einbauanleitung
GB	Installation instructions
F	Consignes de montage
NL	Montagehandleiding
DK	Montagevejledning
N	Monteringsinstruksjon
S	Installationsanvisning
FIN	Asennusohje
I	Istruzioni per il montaggio
E	Instrucciones de montaje
P	Instruções de montagem
GR	Οδηγίες εγκατάστασης
CZ	Návod k montáži
SLO	Navodilo za vgradnjo
SK	Montážny návod
PL	Instrukcja montażu
TR	Montaj talimatı
H	Beépítési útmutató
HR	Upute o ugradnji
BUL	Инструкция за монтаж
RO	Instrucțiuni de montaj
RU	Инструкция по монтажу и установке
LT	Montavimo informacija
LV	Iemontēšanas pamācība
EST	Paigaldusjuhend

705673

CITROEN/FIAT/PEUGEOT/TOYOTA

- **Jumpy / Jumpy Kombi** 01/07>>
- **Dispatch / Dispatch Kombi** 01/07>>
- **Scudo / Scudo Panorama** 01/07>>
- **Expert / Expert Tepee** 02/07>>
- **Expert Tepee Outdoor** 02/07>>
- **Proace** 04/13>>

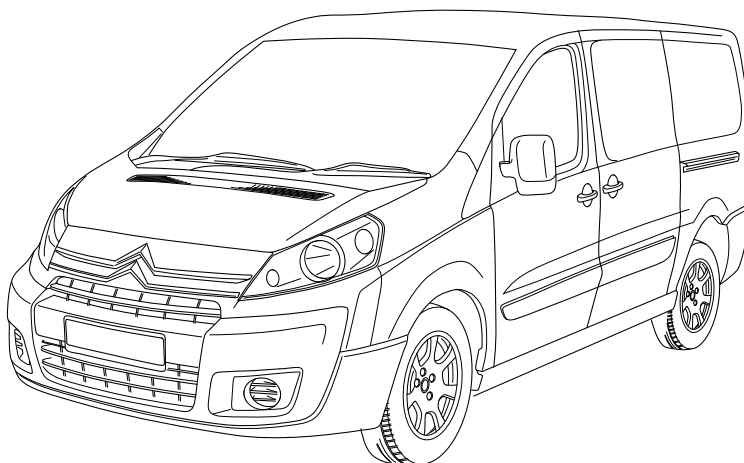

KIT

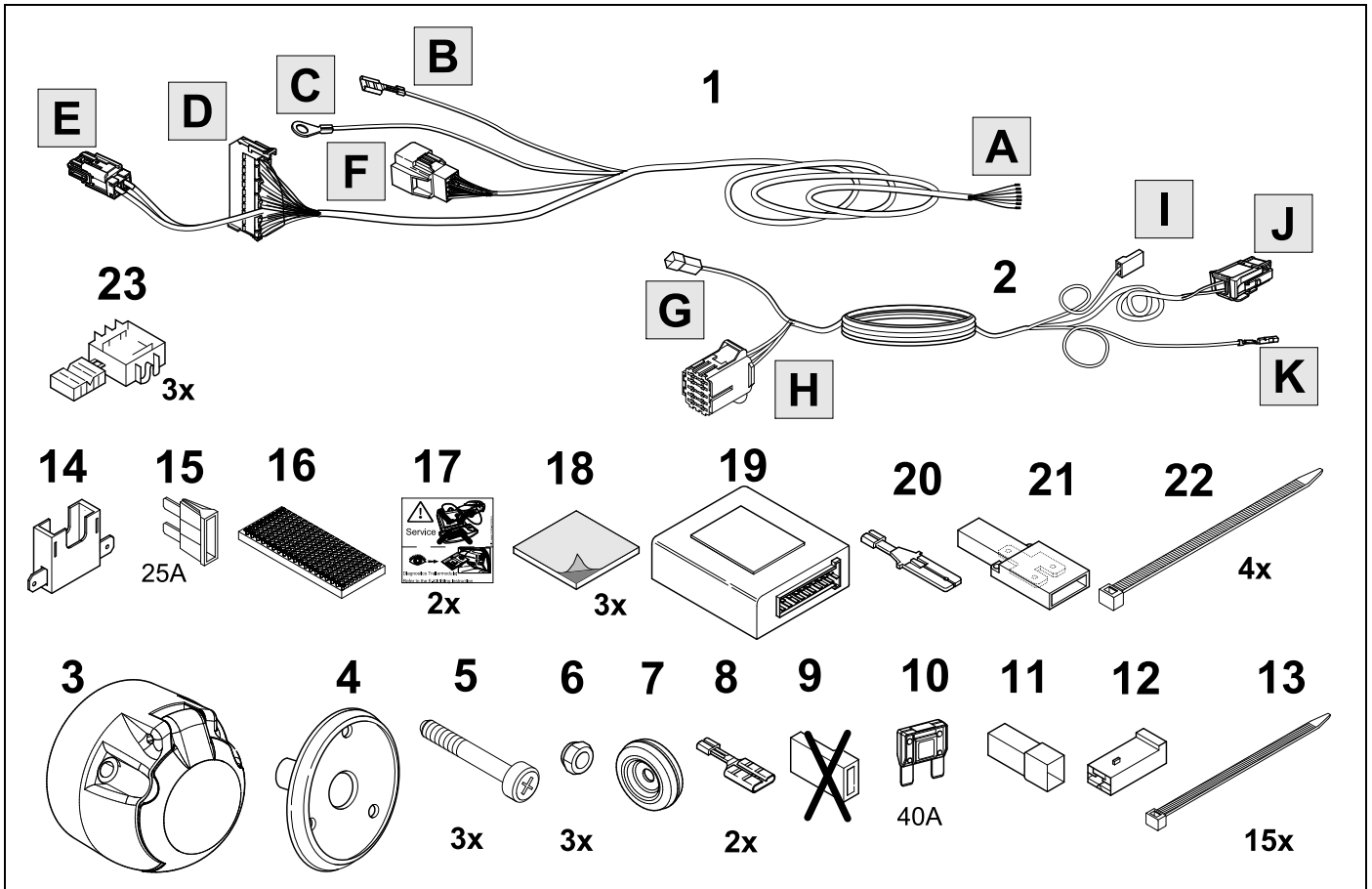

TOOLS

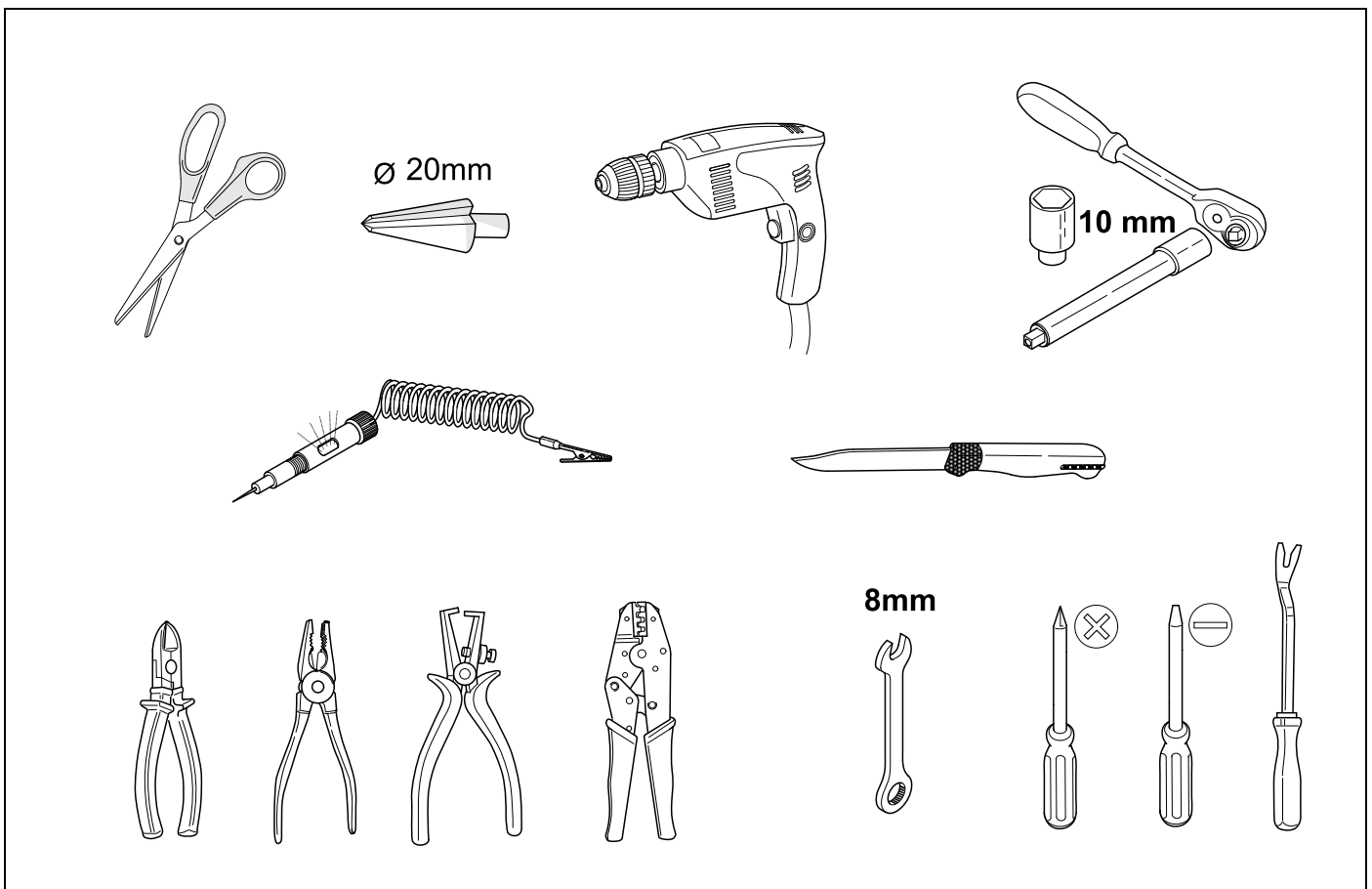

1

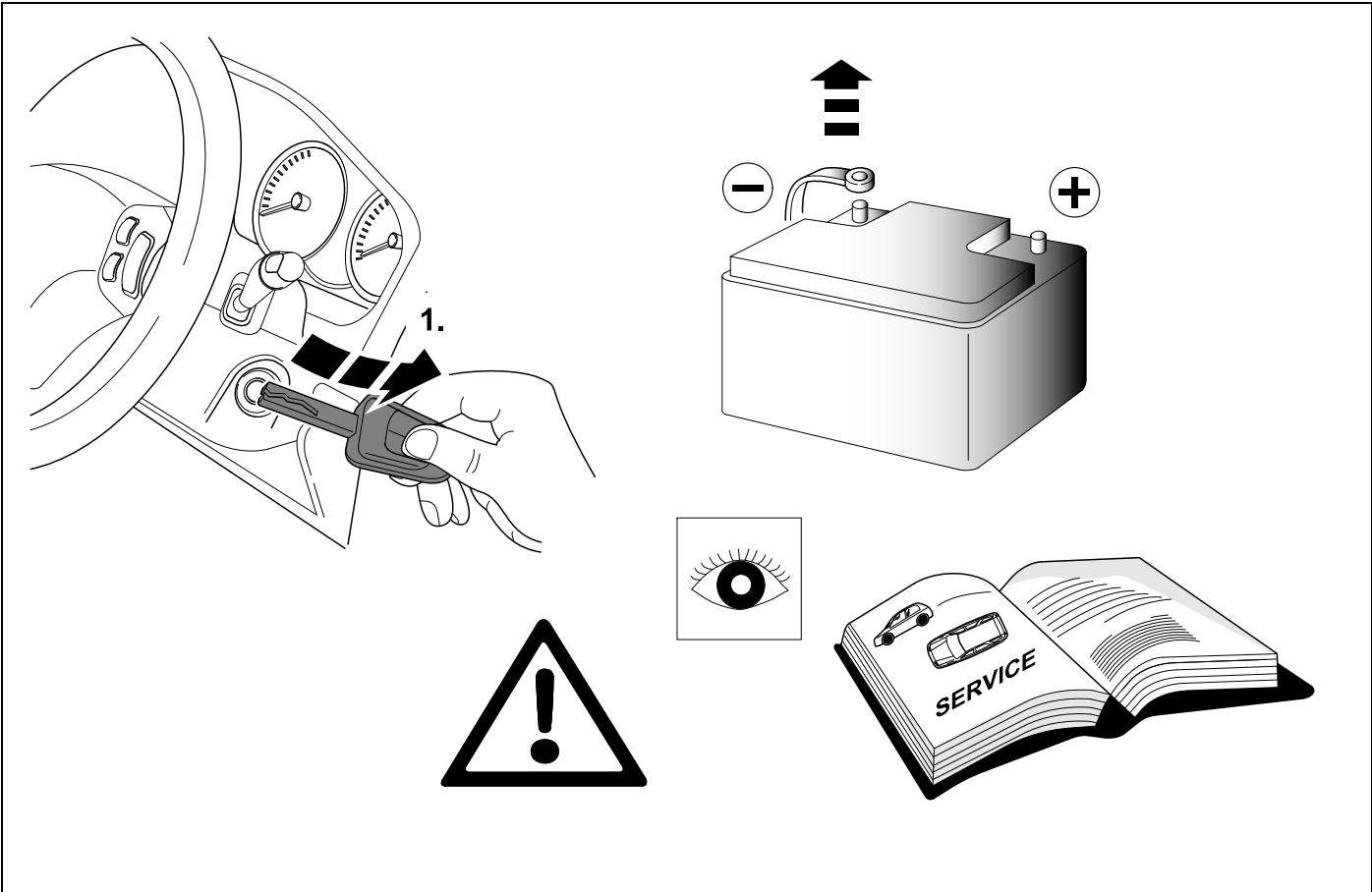

2

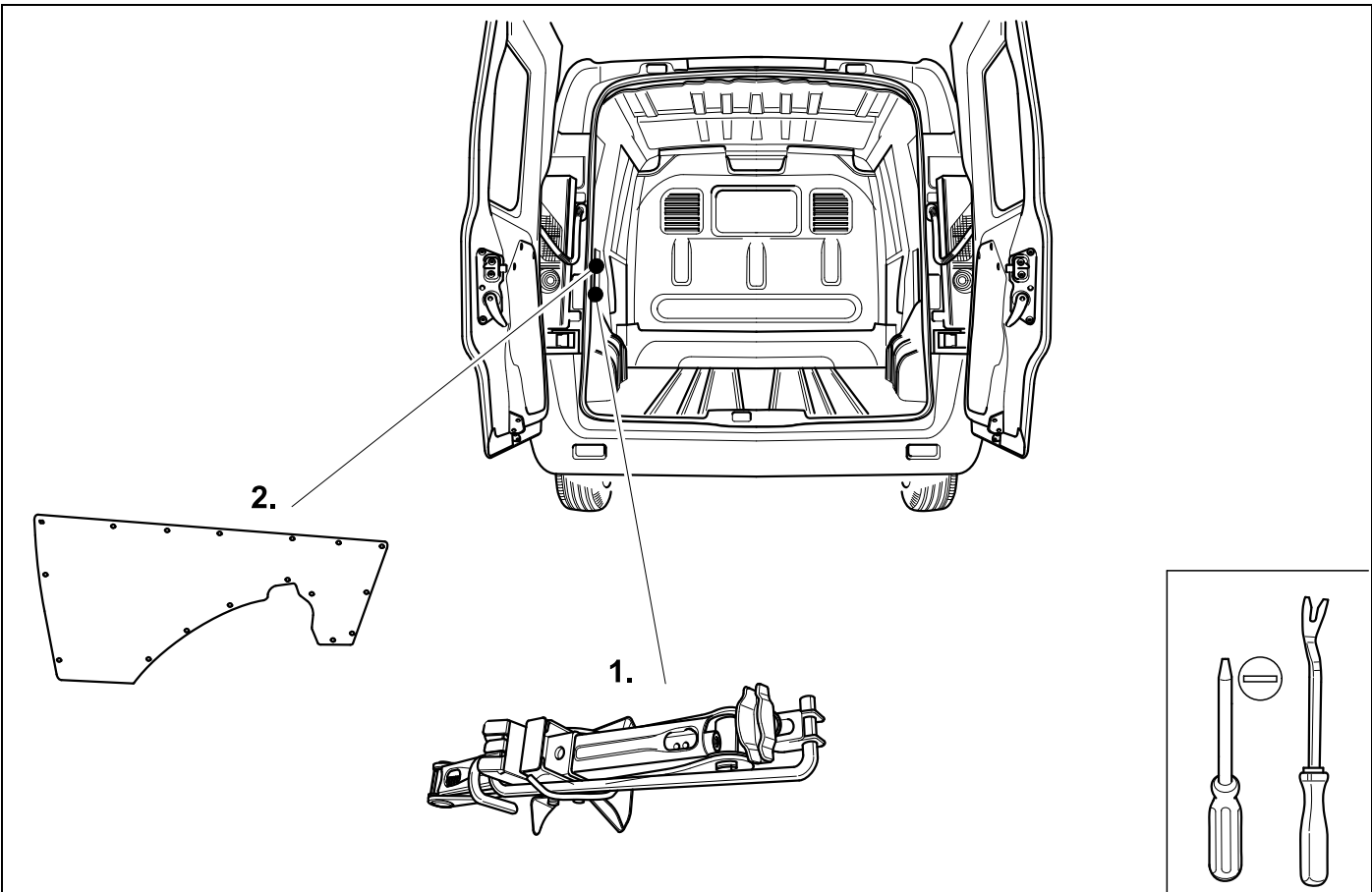

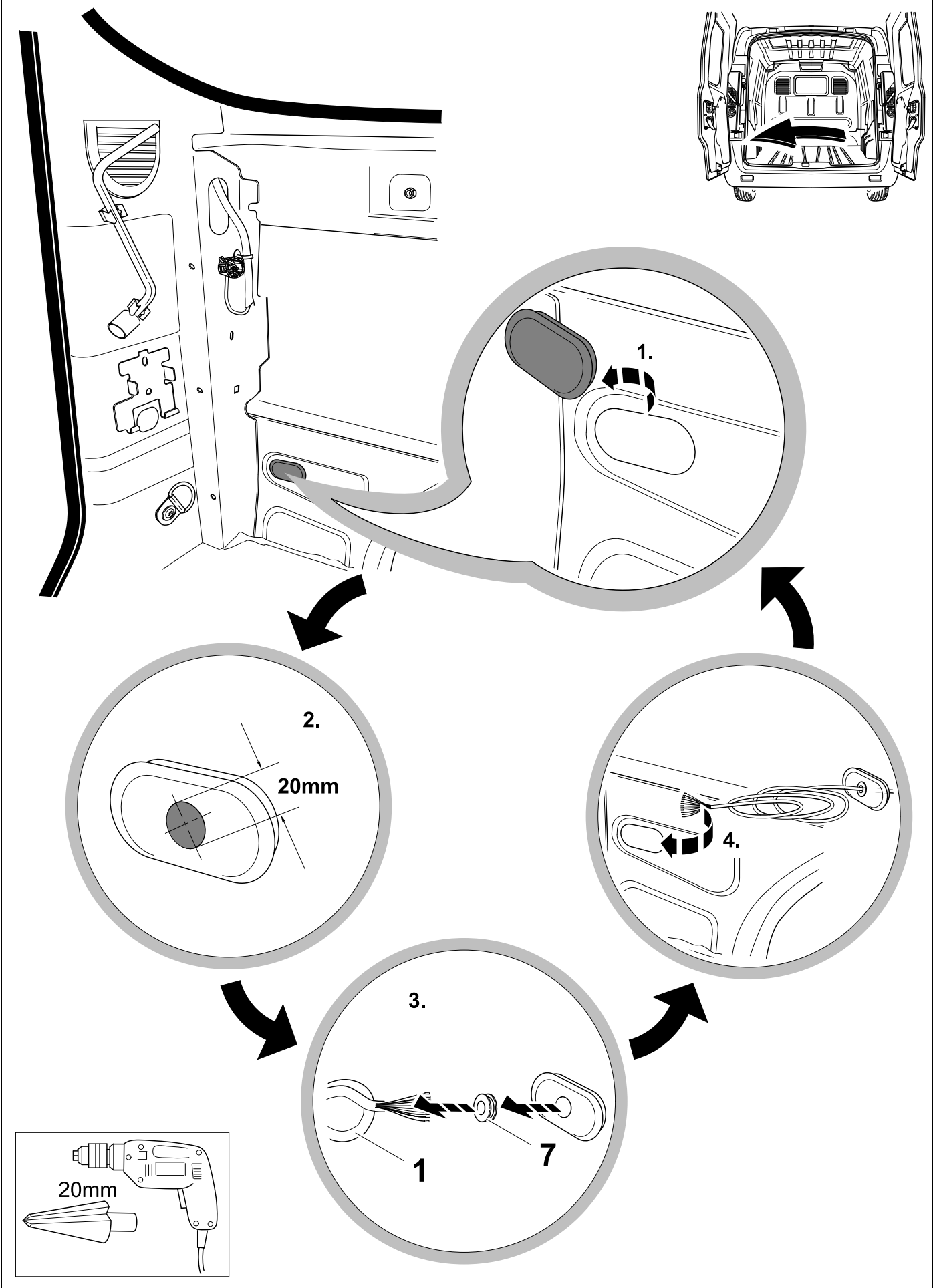

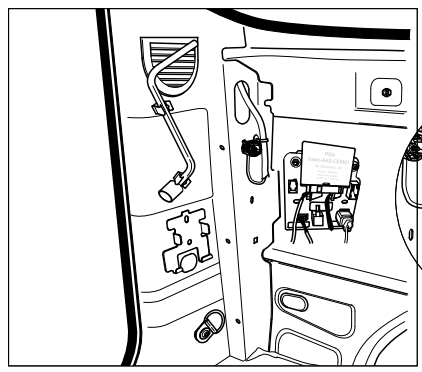
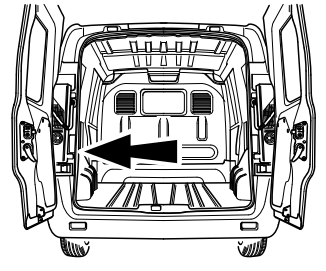

OPTION A

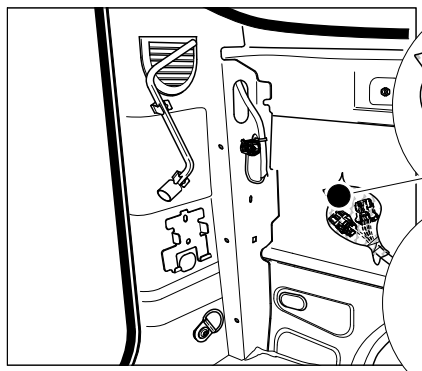
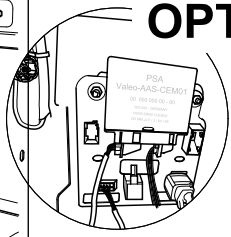

OPTION B

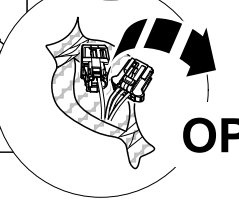

OPTION 1

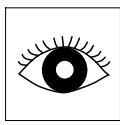
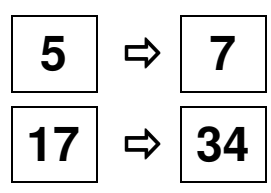

OPTION 2

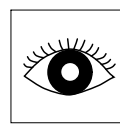
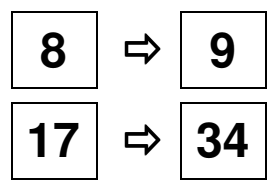

OPTION 3

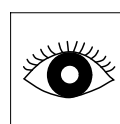
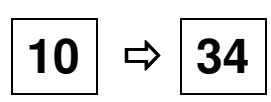

5

OPTION 1

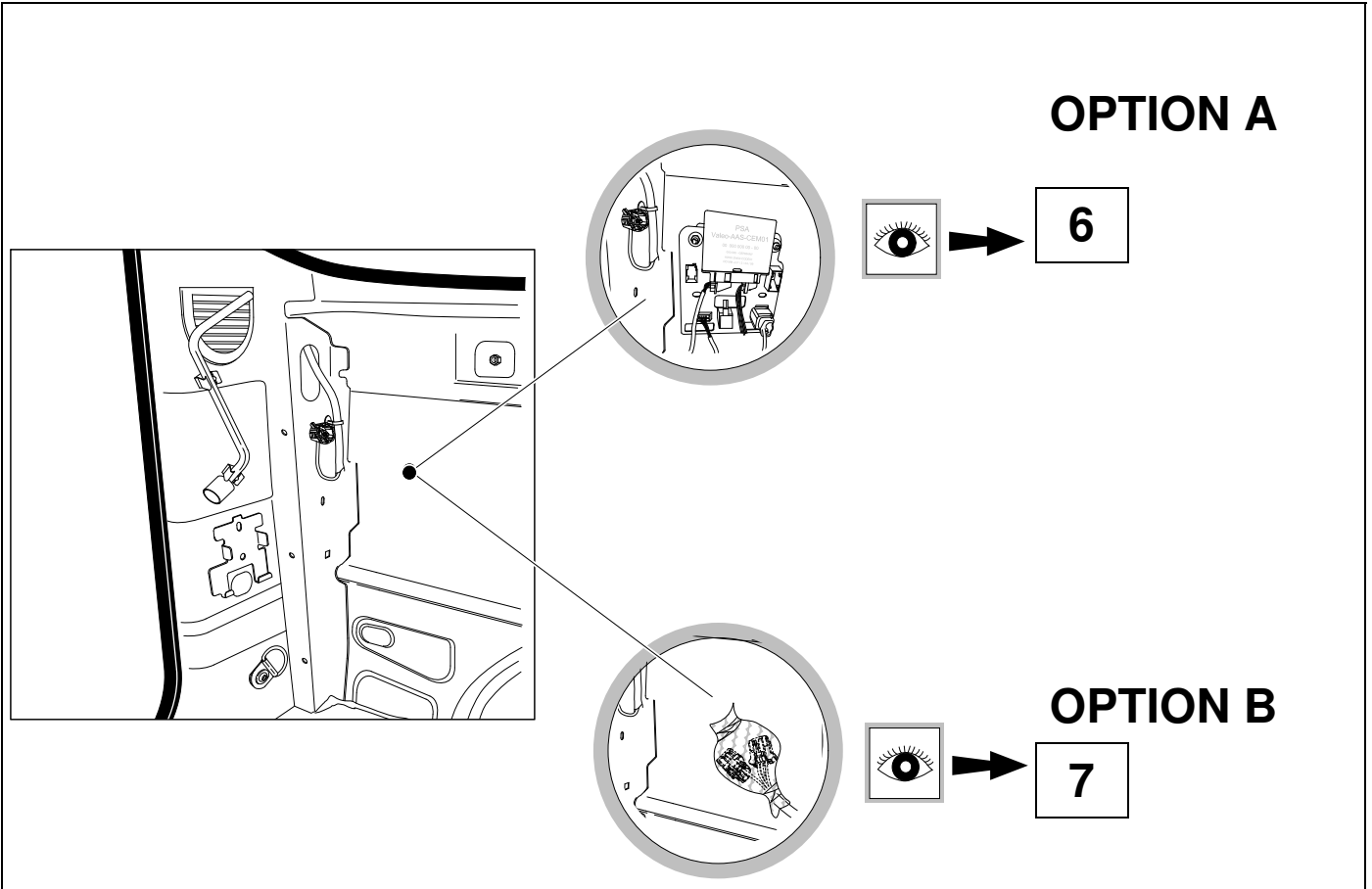

6



22

OPTION A

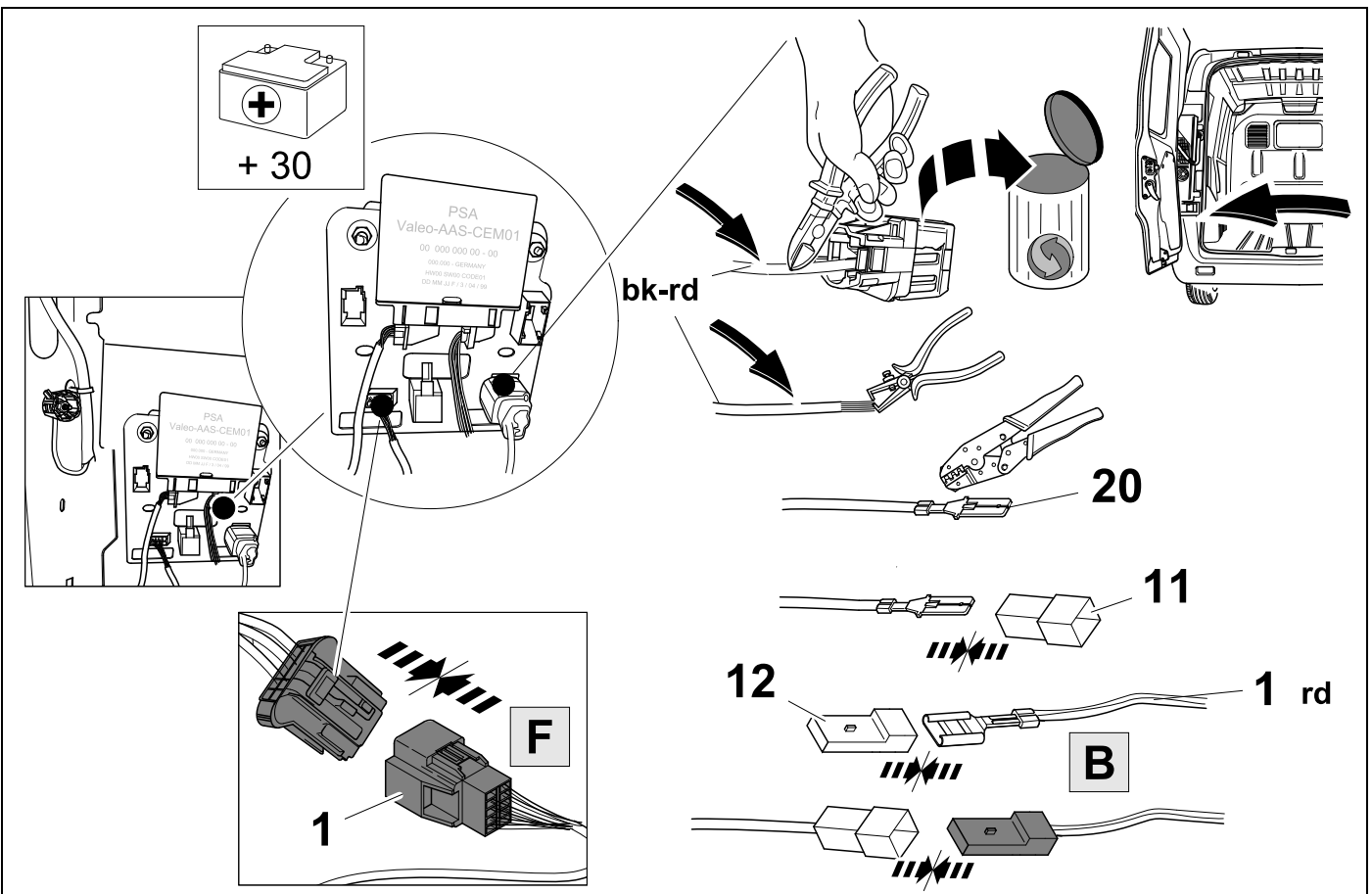

7

👁️ ➔ 22

OPTION B

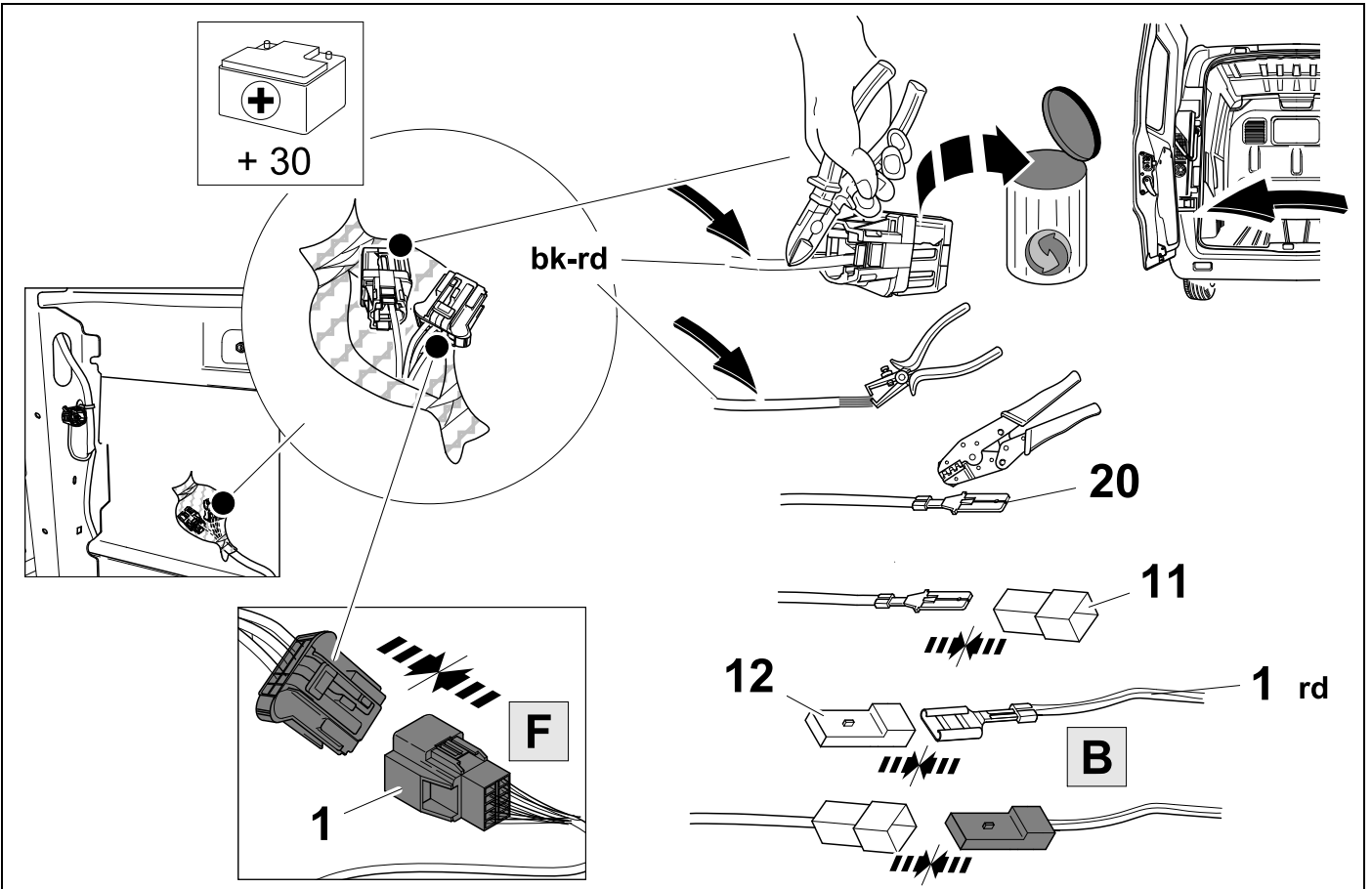

8

👁️ ➔ 22

OPTION 2

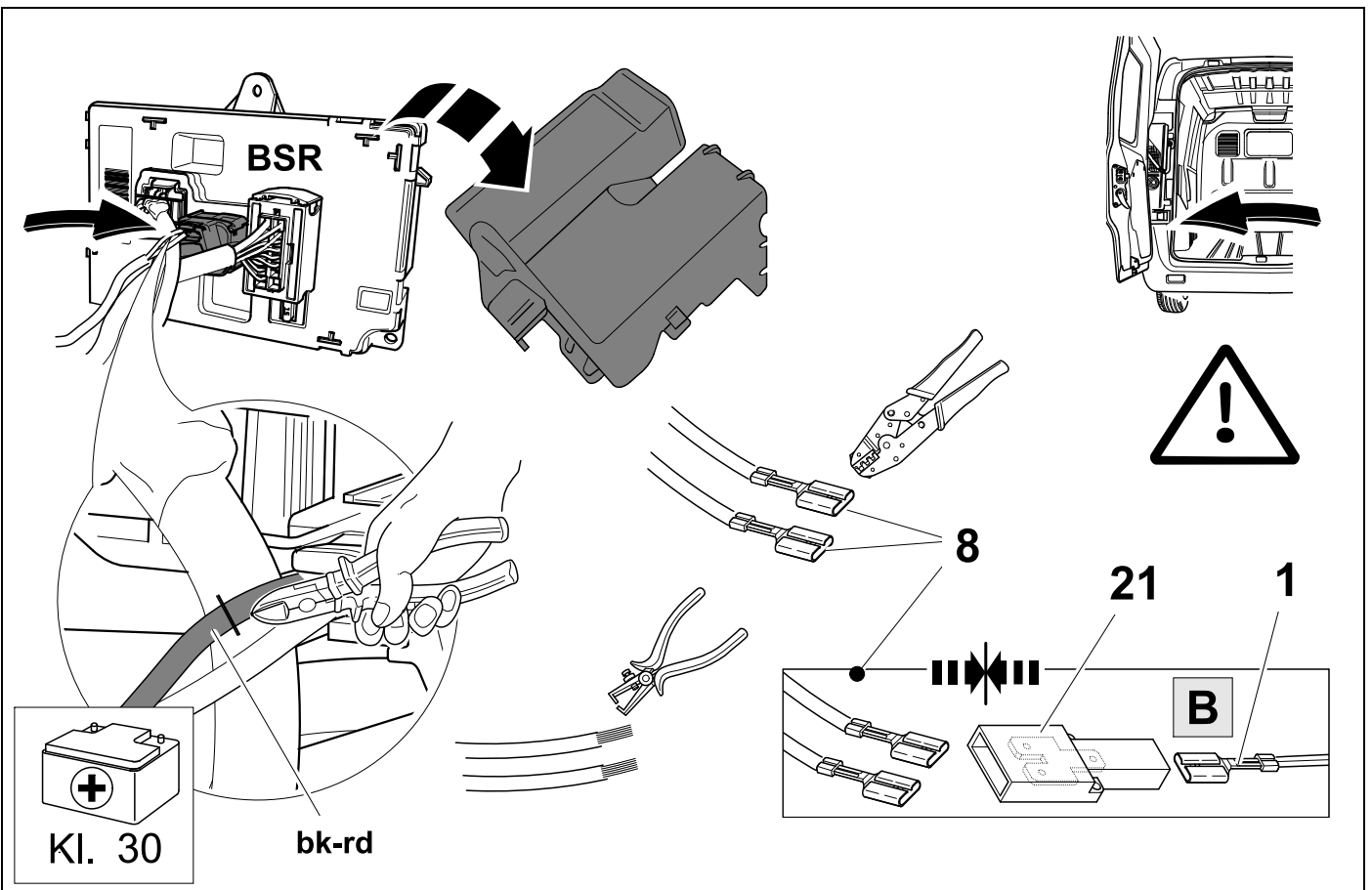

9

OPTION 2

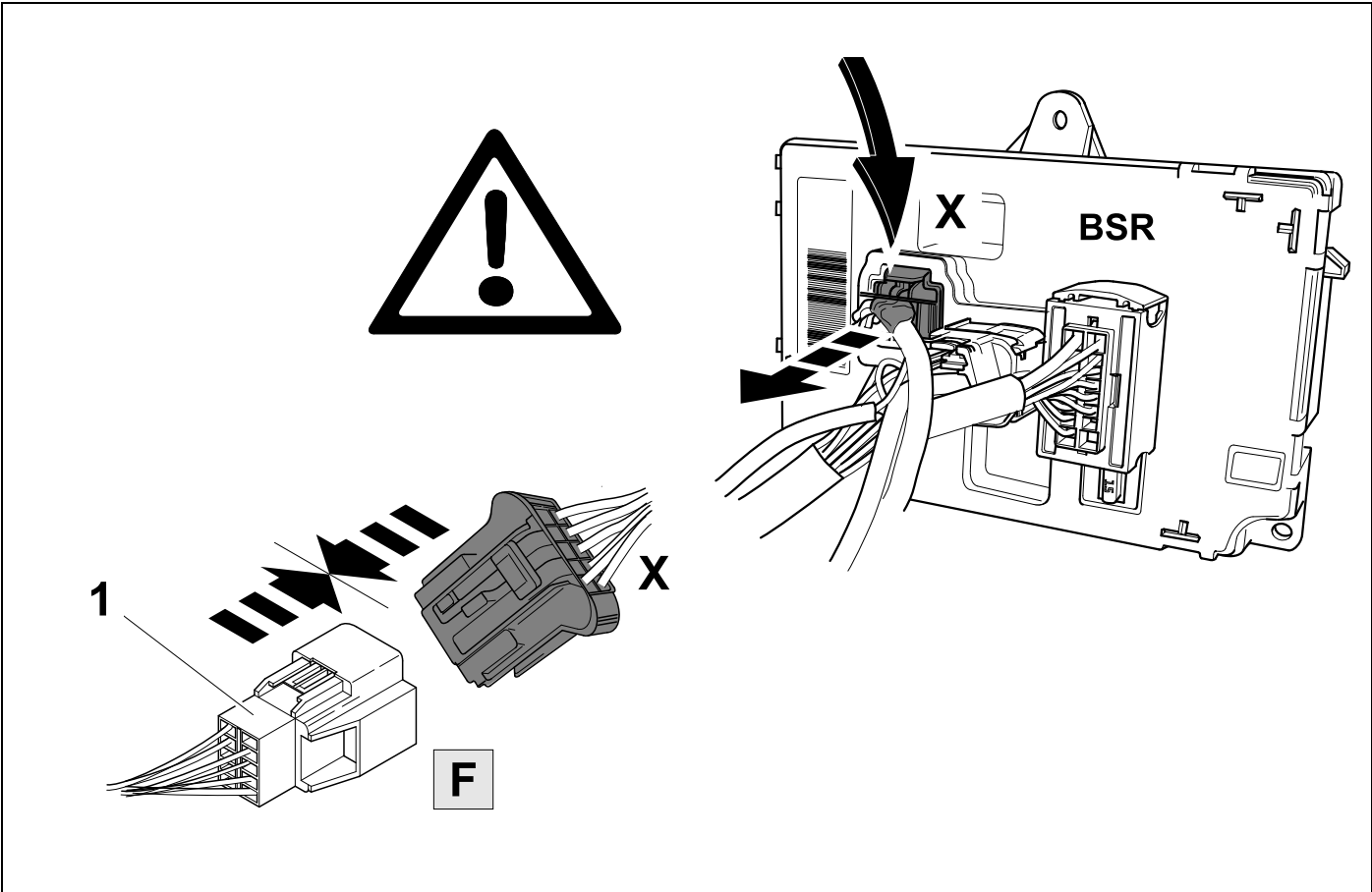

10

OPTION 3

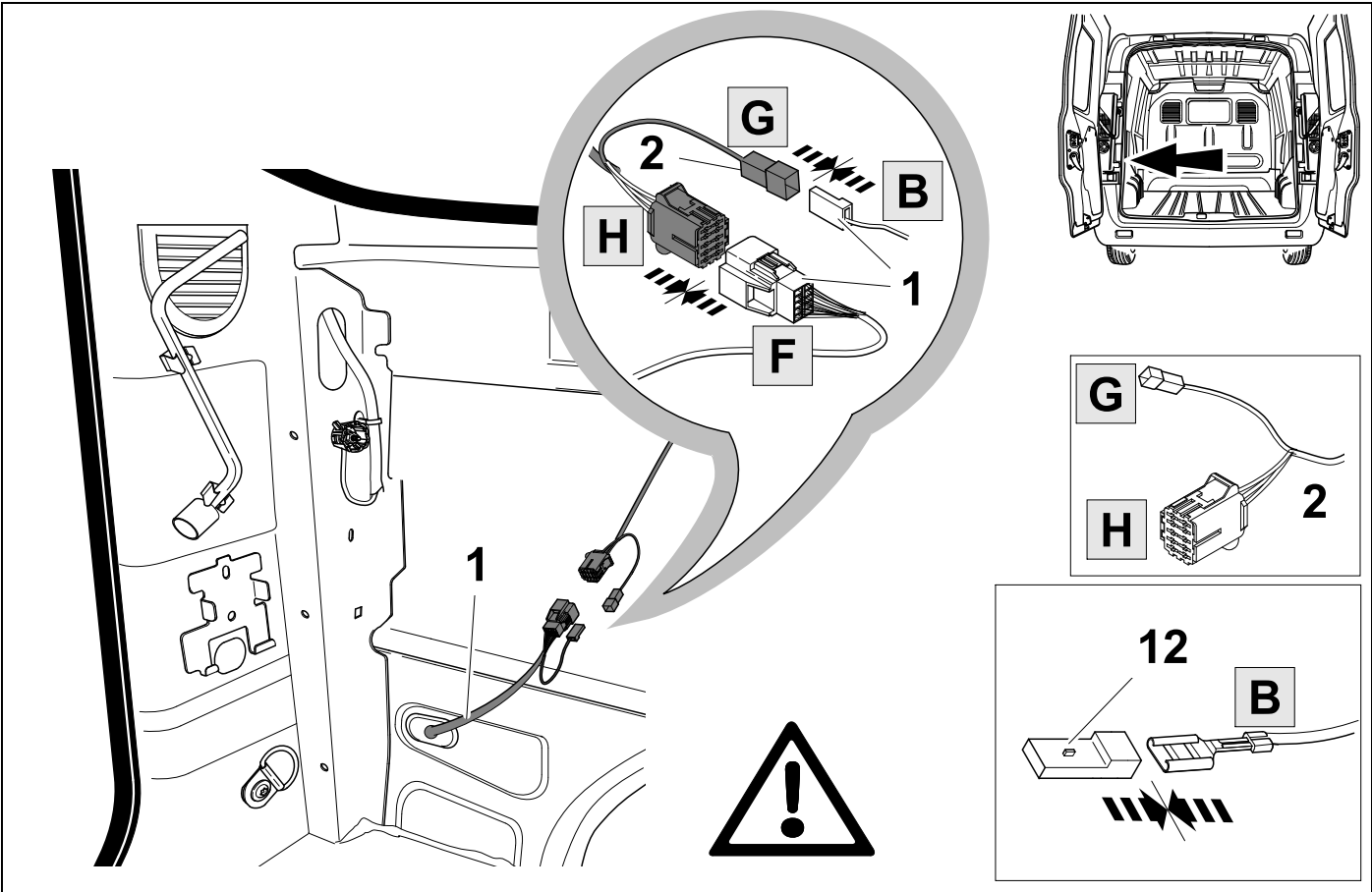

11

OPTION 3

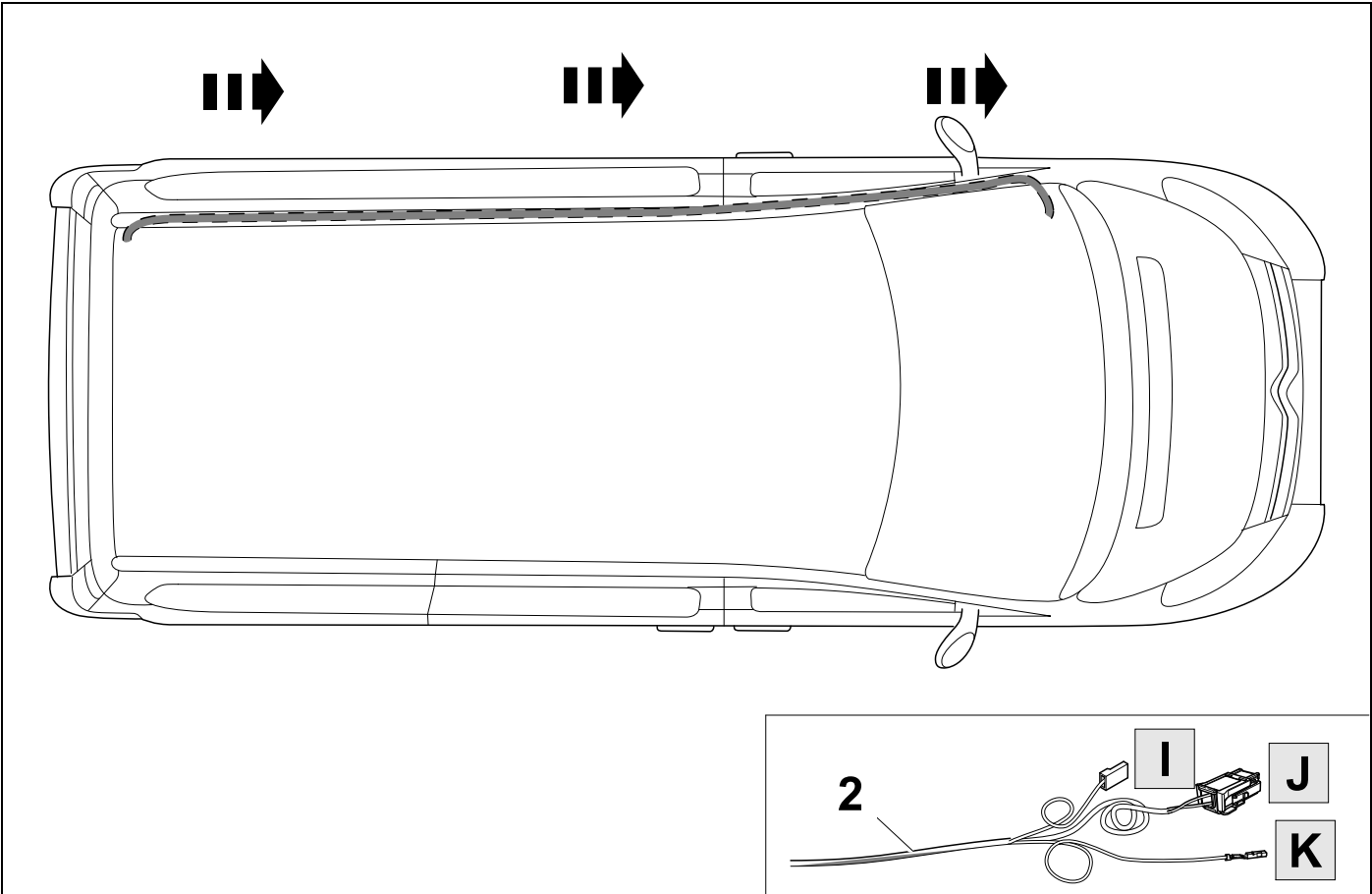

12

OPTION 3

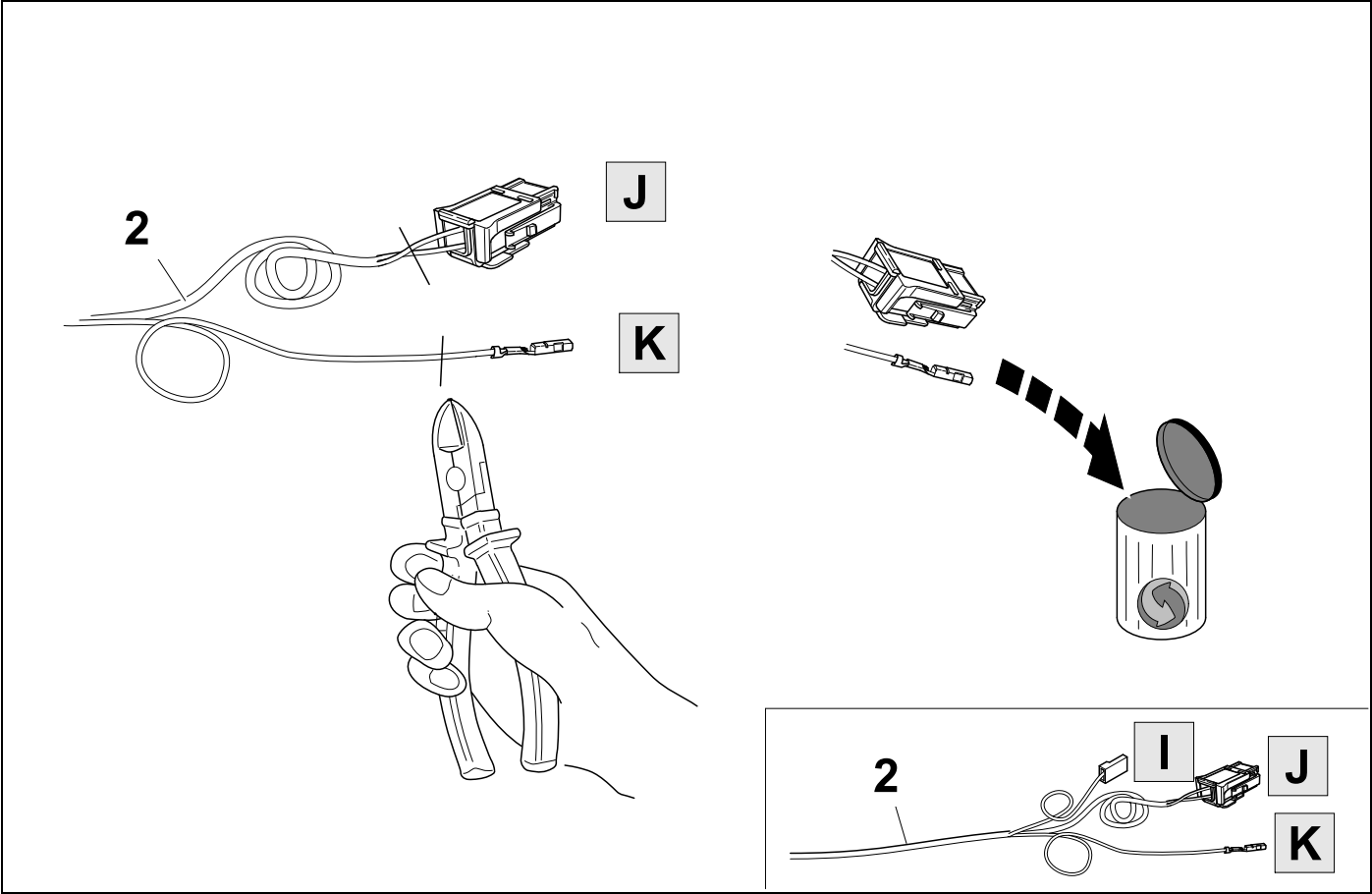

13

👁️ → 22

OPTION 3

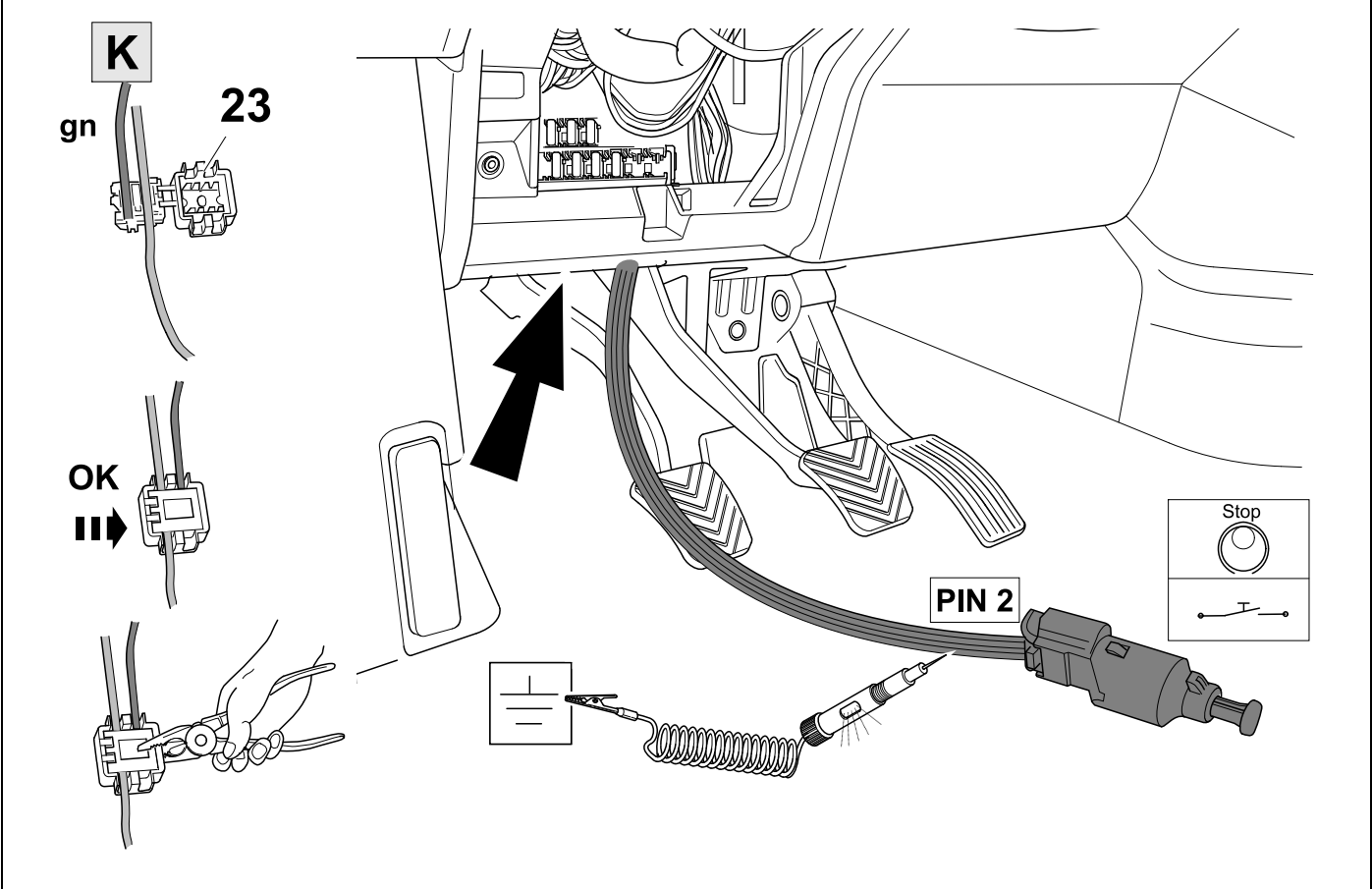

14

👁️ → 22

OPTION 3

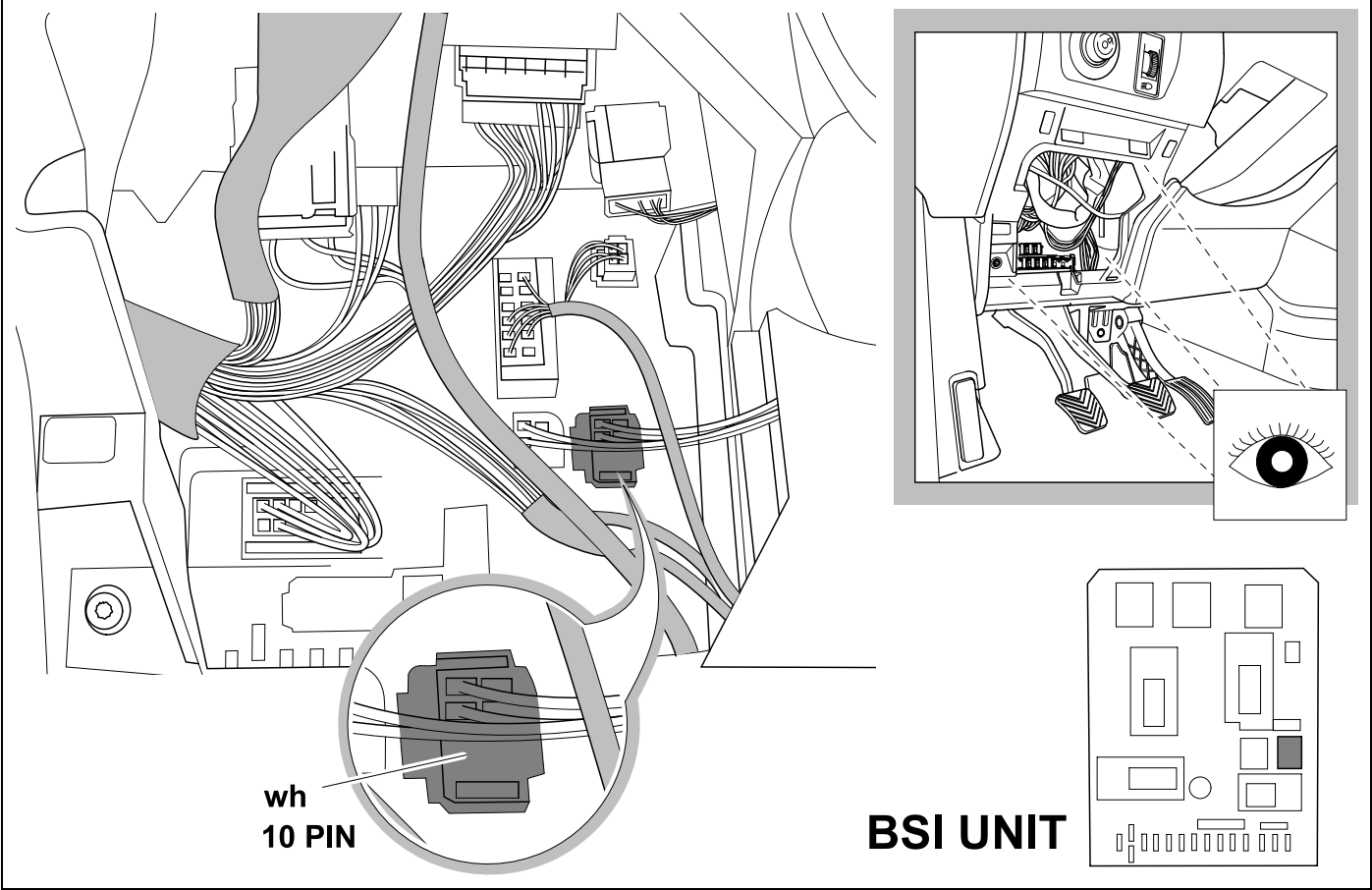

15

👁️ ➔ 22

OPTION 3

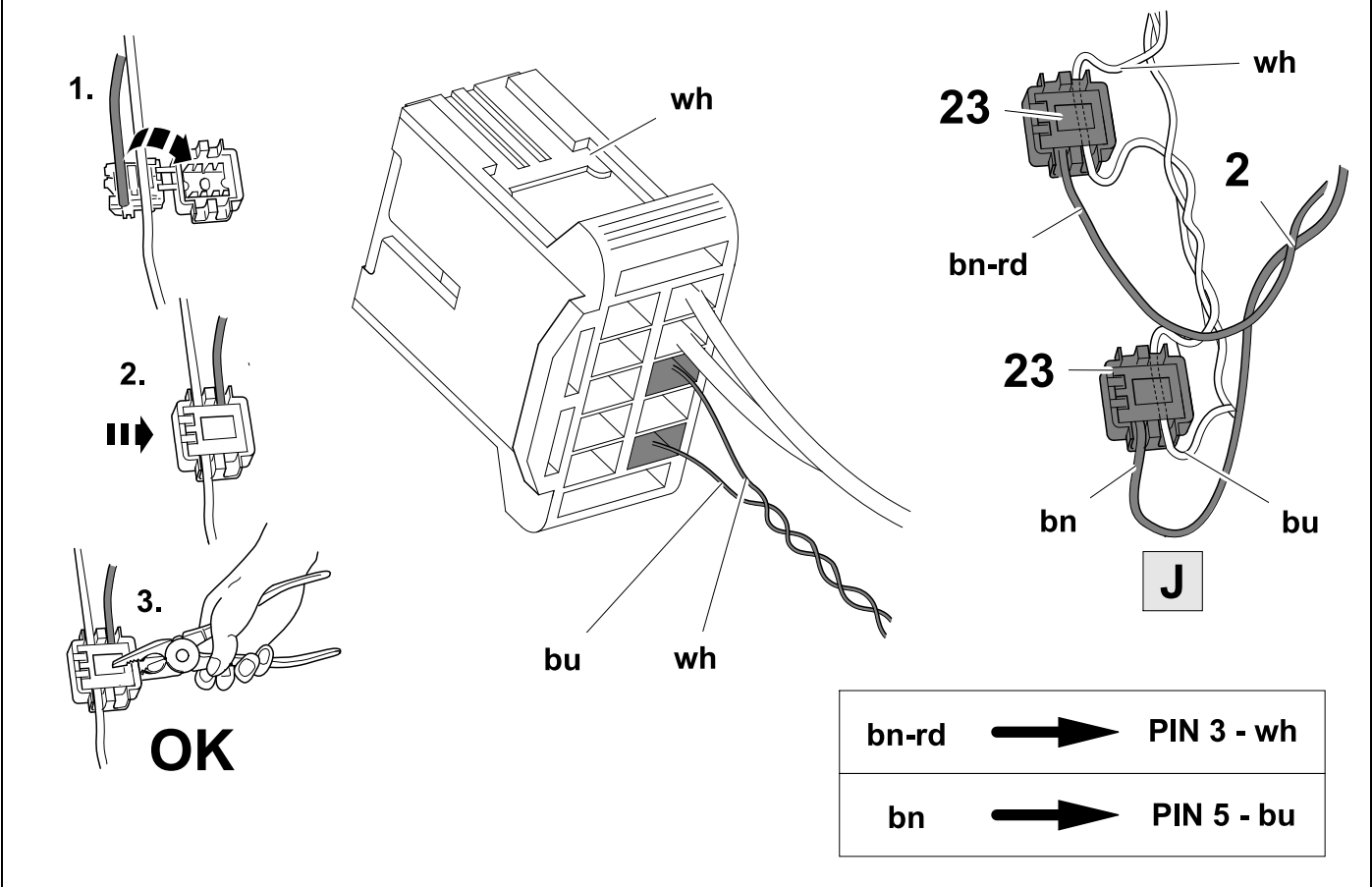

16

👁️ ➔ 28

OPTION 3

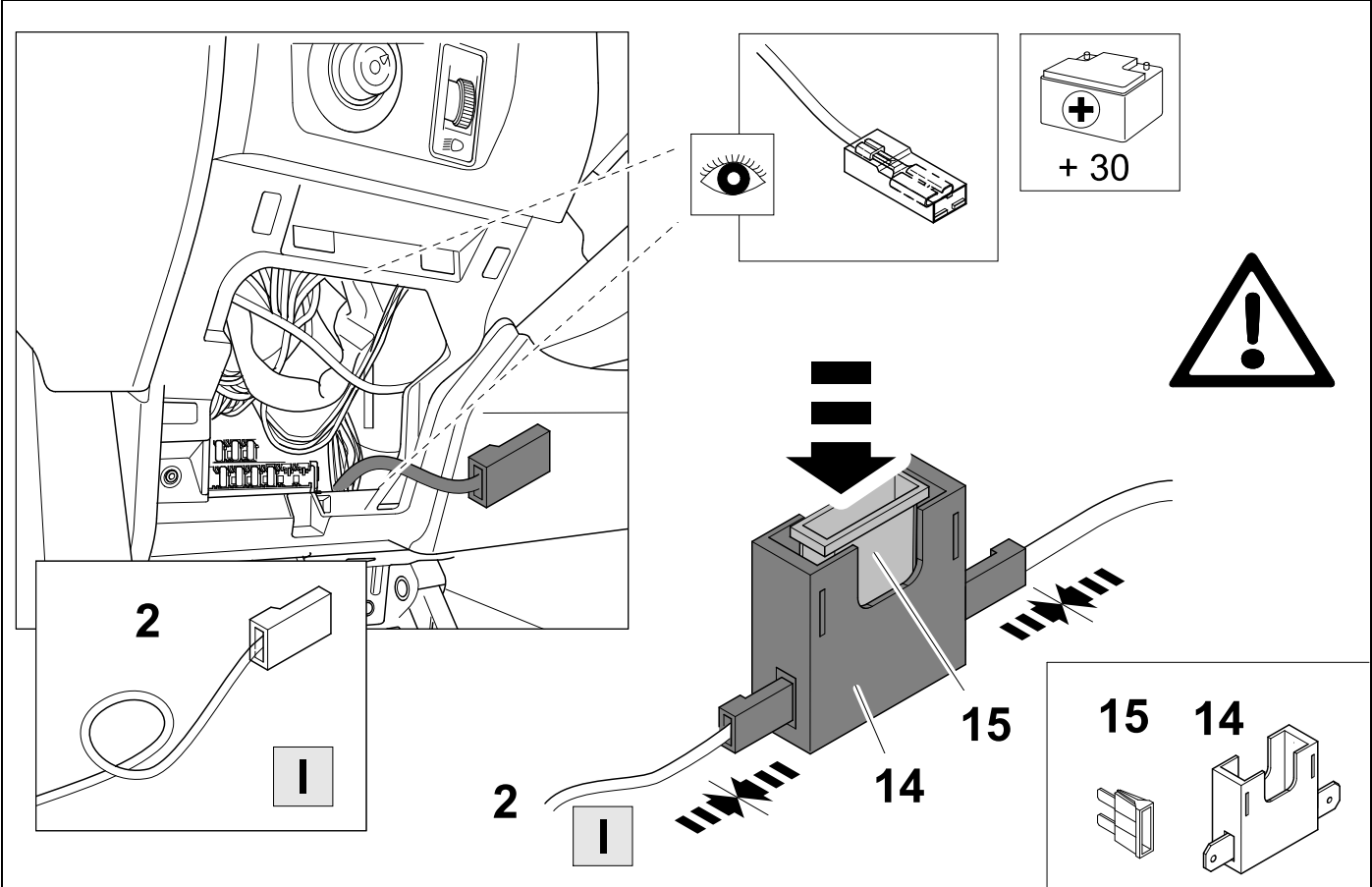

17



28

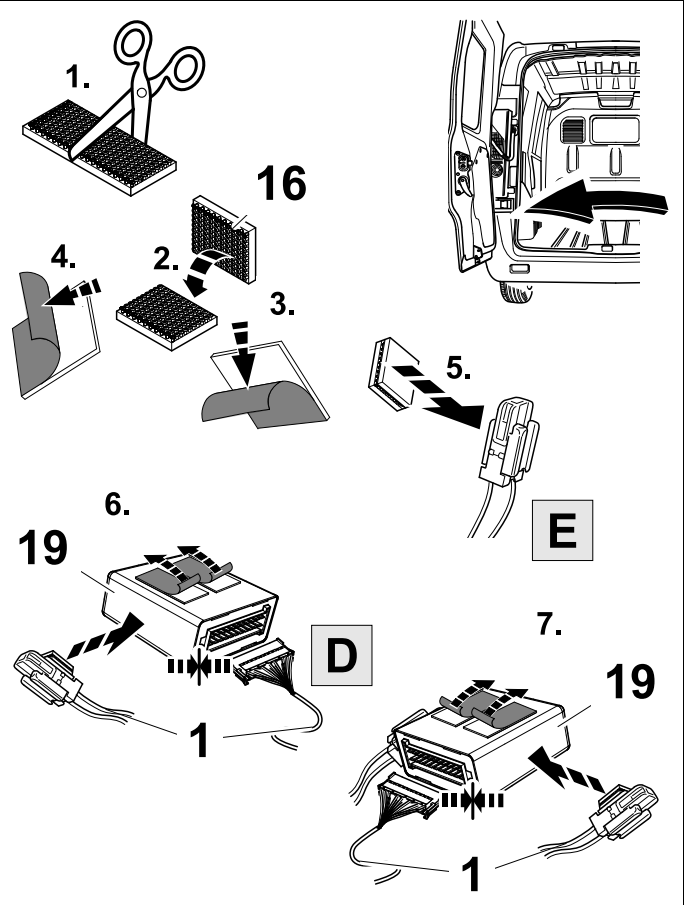
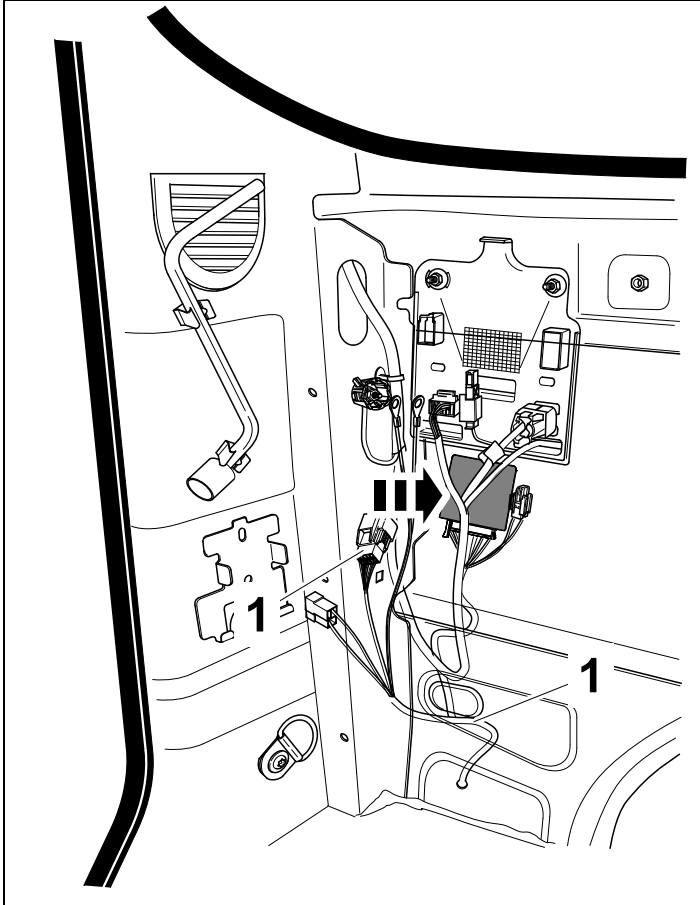

18

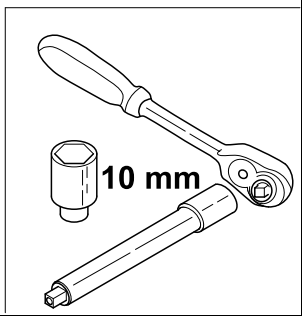
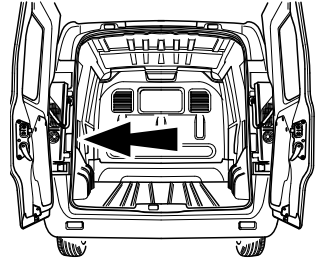
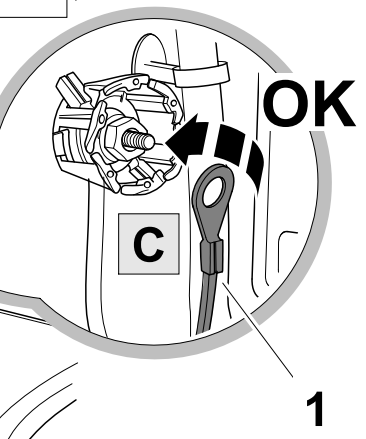
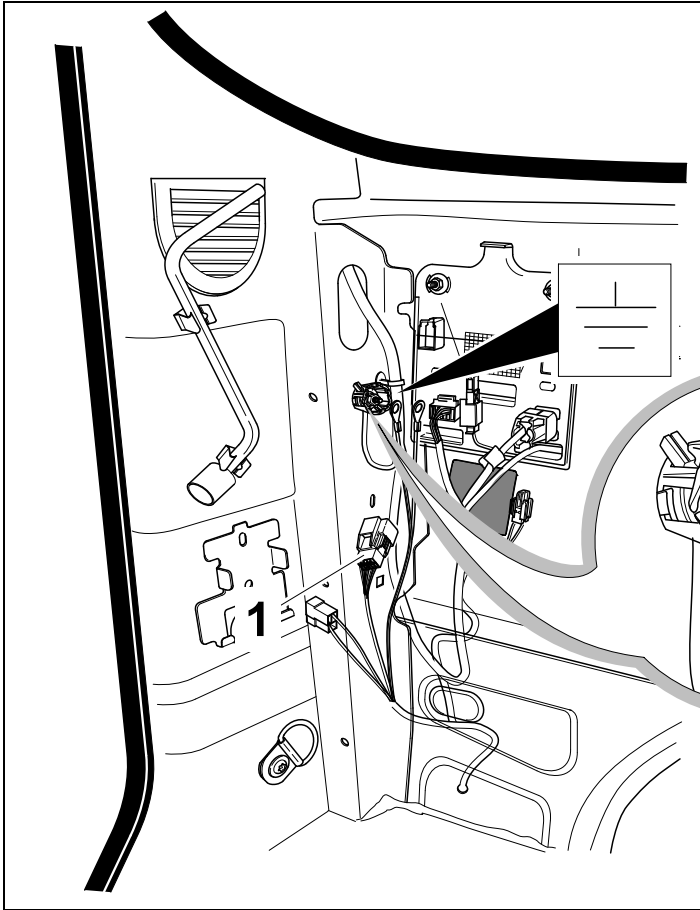

19



27

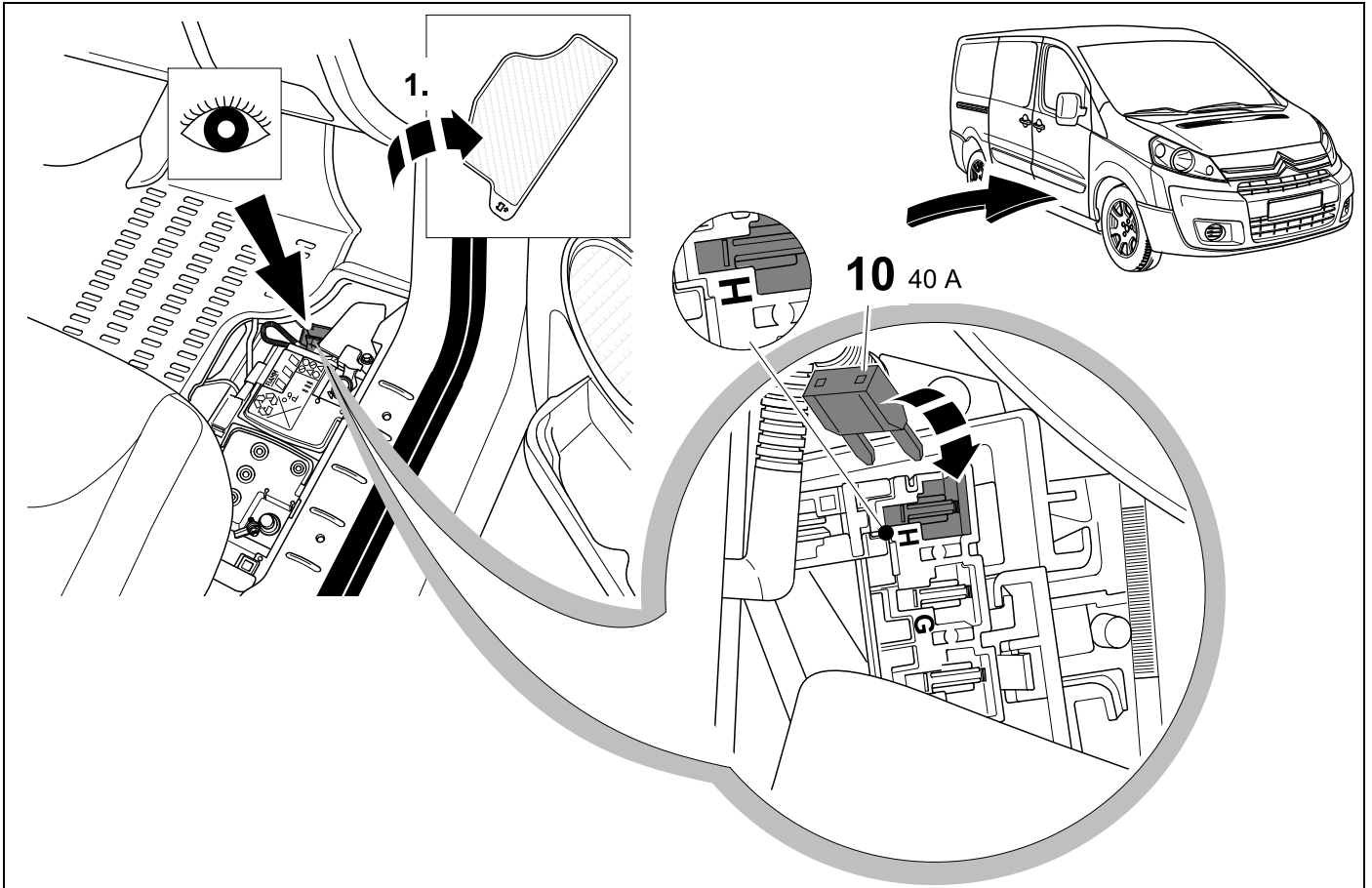

20



21

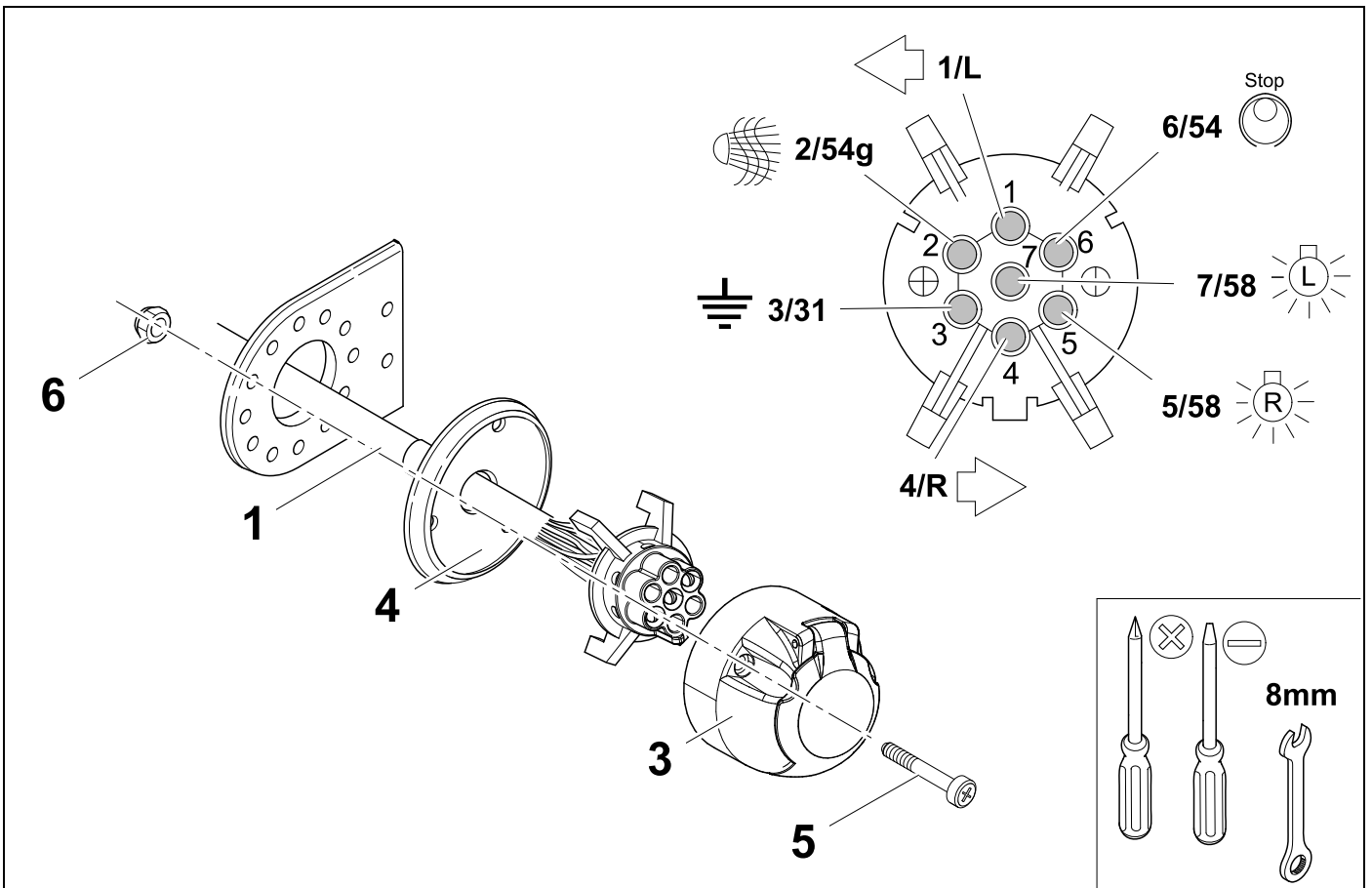



1/L	bk/wh	
2/54g	gy	
3/31	wh/bn	
4/R	bk/gn	
5/58R	gy/rd	
6/54	bk/rd	
7/58L	gy/bk	

22	bk	wh	gy	gn	rd	bu	ye	bn	pu	or	no
(D)	schwarz	weiß	grau	grün	rot	blau	gelb	braun	violett	orange	nicht belegt
(GB)	black	white	grey	green	red	blue	yellow	brown	purple	orange	not occupied
(F)	noir	blanc	gris	vert	rouge	bleu	jaune	brun	violet	orange	inutilisé
(NL)	zwart	wit	grijs	groen	rood	blauw	geel	bruin	violet	oranje	niet aangesloten
(DK)	sort	hvid	grå	grøn	rød	blå	gul	brun	violet	orange	ikke anvendt
(N)	svart	hvit	grå	grønn	rød	blå	gul	brun	fiolett	oransje	ikke i bruk
(S)	svart	vit	grå	grön	röd	blå	gul	brun	violett	orange	ej använd
(FIN)	musta	valkoinen	harmaa	vihreä	punainen	sininen	keltainen	ruskea	violetti	oranssi	ei varattu
(I)	nero	bianco	grigio	verde	rosso	blu	giallo	marrone	viola	arancione	libero
(E)	negro	blanco	gris	verde	rojo	azul	amarillo	marrón	violeta	anaranja-do	no ocupado
(P)	preto	branco	cinzento	verde	vermelho	azul	amarelo	castanho	violeta	laranja	não ocupado
(GR)	μαύρος	λευκός	Γκρι	πράσινος	κόκκινος	μπλε	κίτρινος	καφέ	Μωβ	πορτοκαλί	δεν είναι κατ'επιλημμένος
(PL)	czarny	biały	szaro	zielony	czerwony	niebiesko	żółty	brazowy	fioletowy	pomarańczowy	wolny
(CZ)	černý	bílý	šedý	zelený	červený	modrý	žlutý	hnědý	fialový	oranžový	neobsazen
(TR)	siyah	beyaz	gri	yeşil	kırmızı	mavi	sarı	kahverengi	mor	portakal rengi	boş
(H)	fekete	fehér	szürke	zöld	piros	kék	sárga	barna	ibolyakék	narancssárga	nem foglalt
(HR)	crno	bijelo	sivo	zeleno	crveno	plavo	zuto	smeđe	ljubičasto	narandžasto	nije zauzeto
(BUL)	черен	бял	сив	зелен	червен	син	жълт	кафяв	виолетов	оранжев	свободно
(RO)	negru	alb	gri	verde	roșu	albastru	galben	maro	violet	portocaliu	liber
(RU)	черный	белый	серый	зеленый	красный	голубой	жёлтый	коричневый	пурпурный	оранжевый	свободно
(LT)	juoda	balta	pilka	žalia	raudona	mėlyna	geltona	ruda	purpurinė	oranžinė	laisva
(LV)	melna	balta	pelēka	zaļa	sarkana	zila	dzeltena	brūna	purpur-sarkana	oranža	brīvs
(EST)	must	valge	hall	roheline	punane	sinine	kollane	pruun	purpur-punane	oraanž	vaba
(SLO)	črna	bela	siva	zelena	rdeča	modra	rumena	smeđ	vijoličast	oranžen	ni zasedeno
(SK)	čierny	biely	šedý	zelený	červený	modrý	žltý	hnědý	fialový	pomaraňový	neobsadený

23

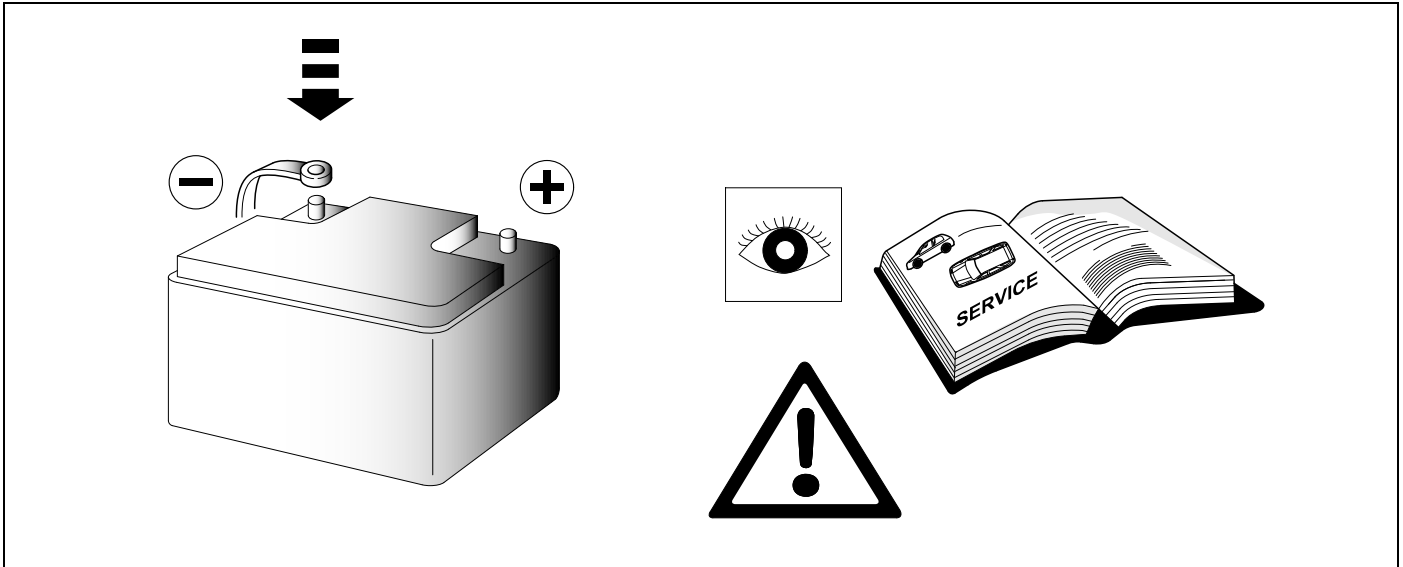

24 CHECK

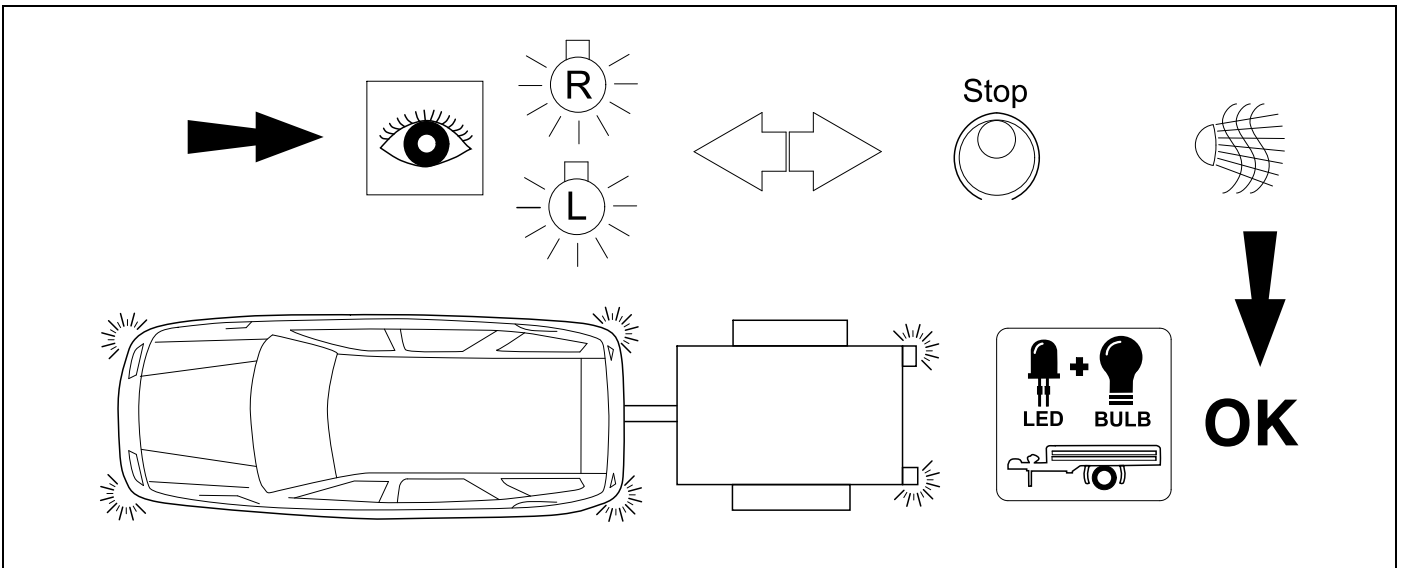

25 OPTIONAL



26 CHECK

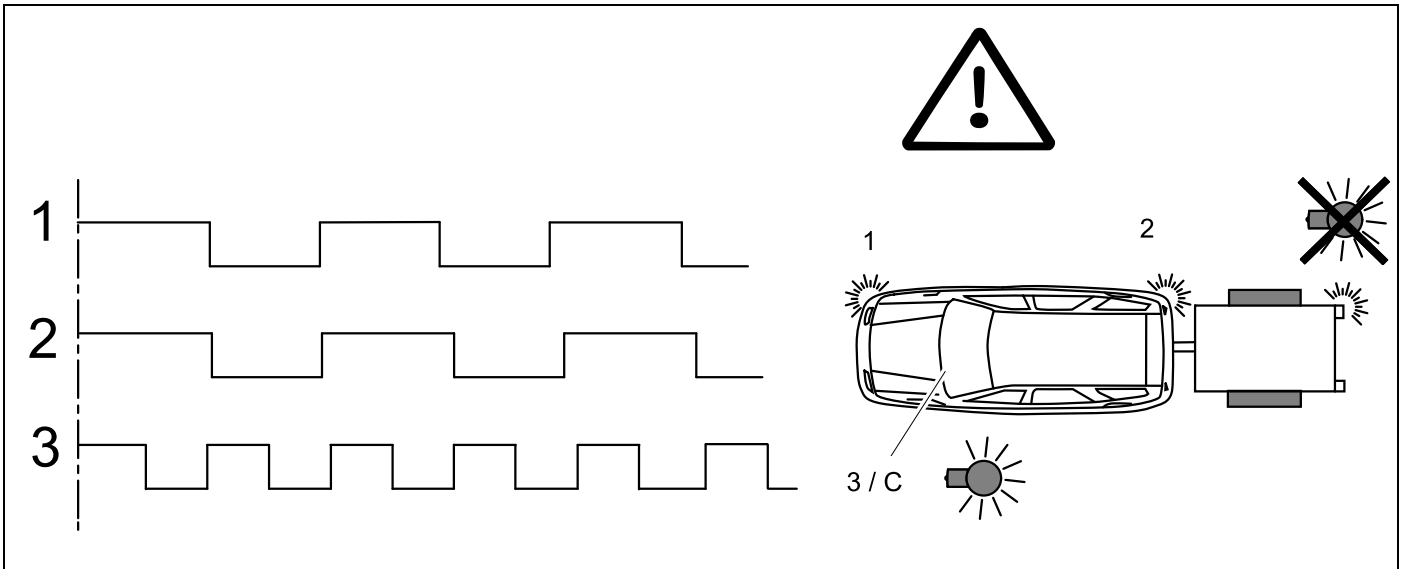

27 Information Service ⇨ 19

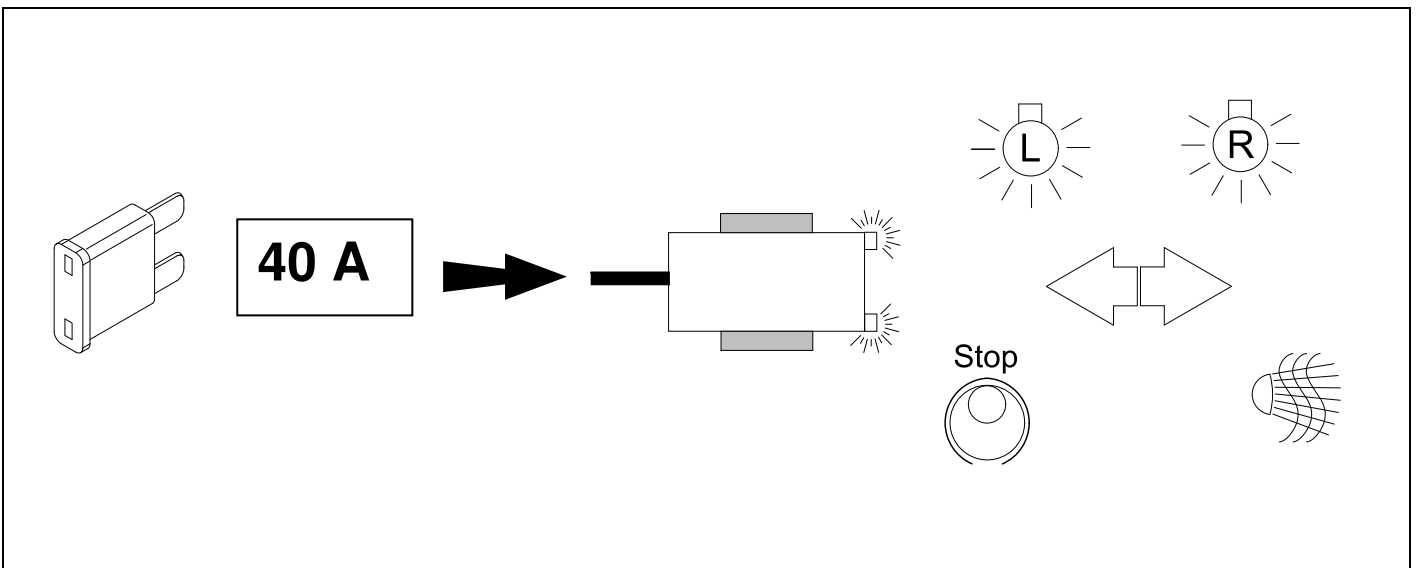

28 Information Service ⇨ 16 + 17

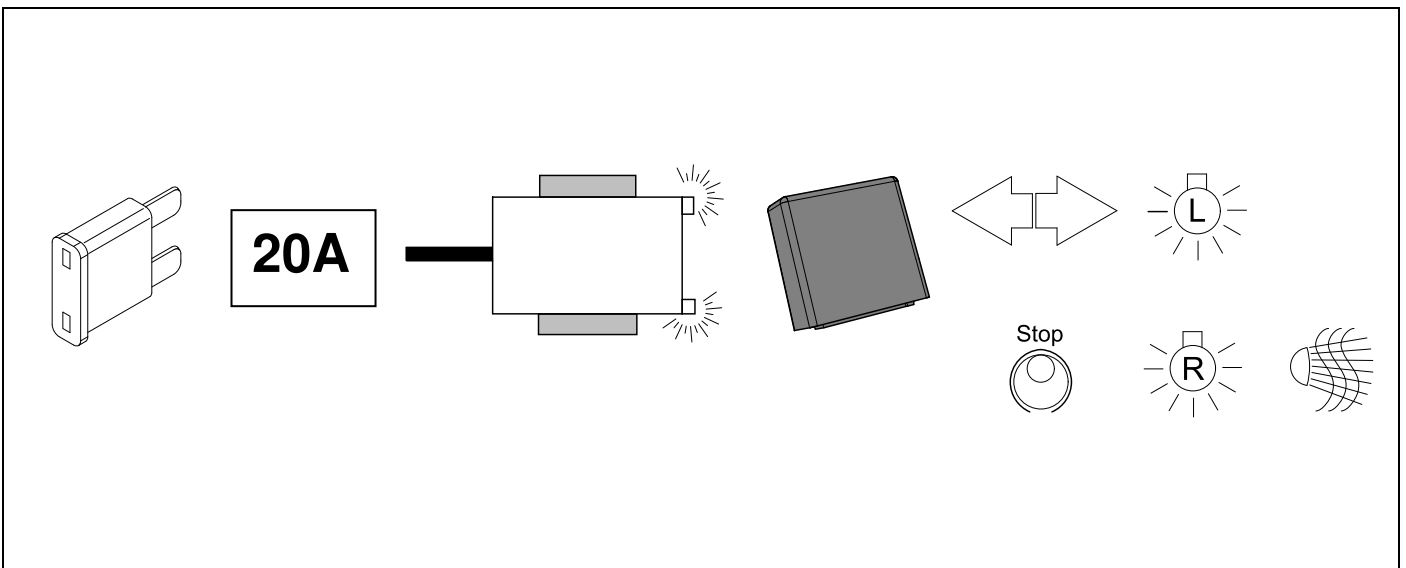

29 OPTIONAL

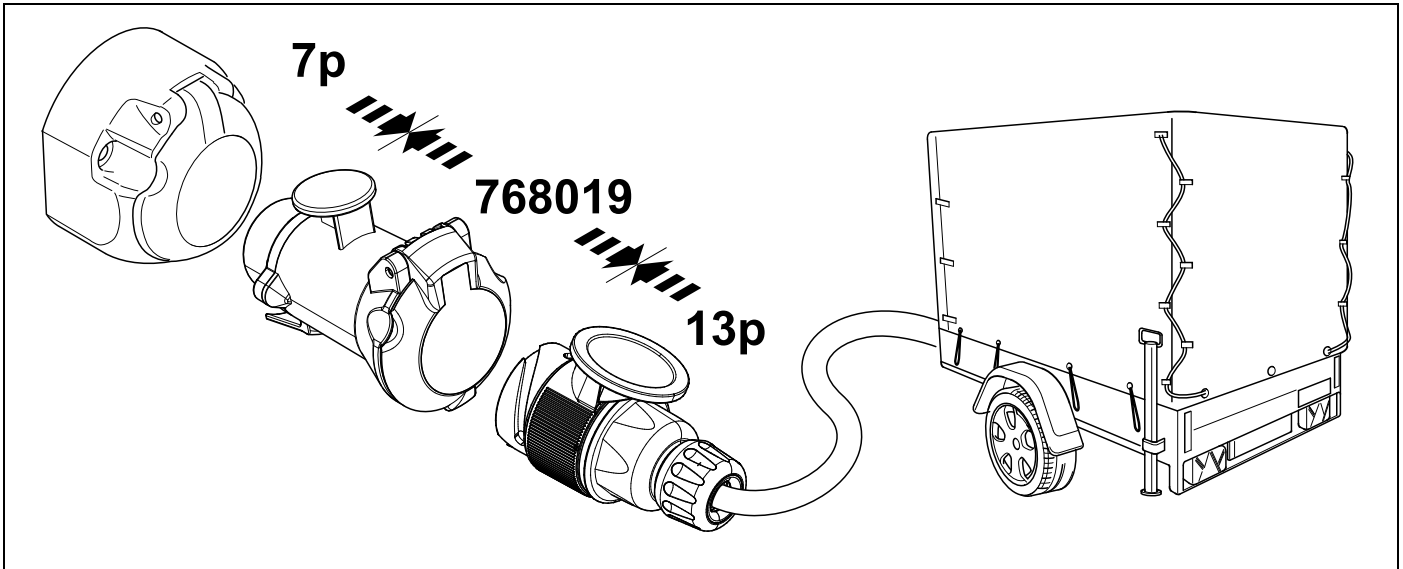

30 PLEASE NOTICE

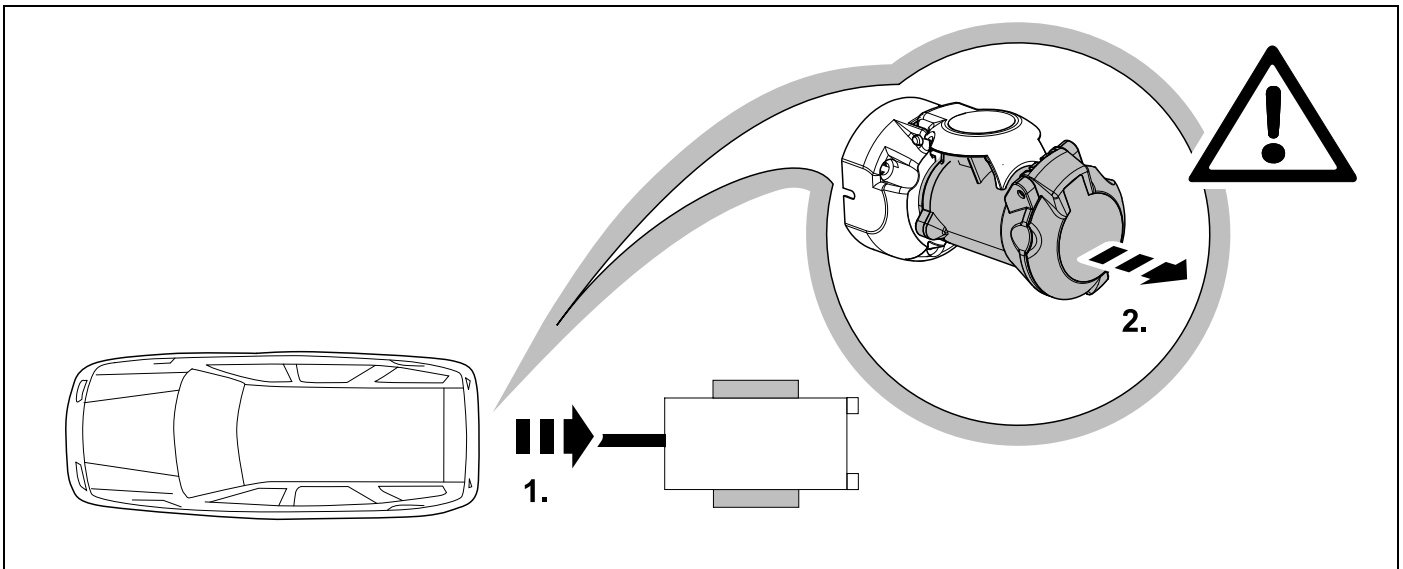

31

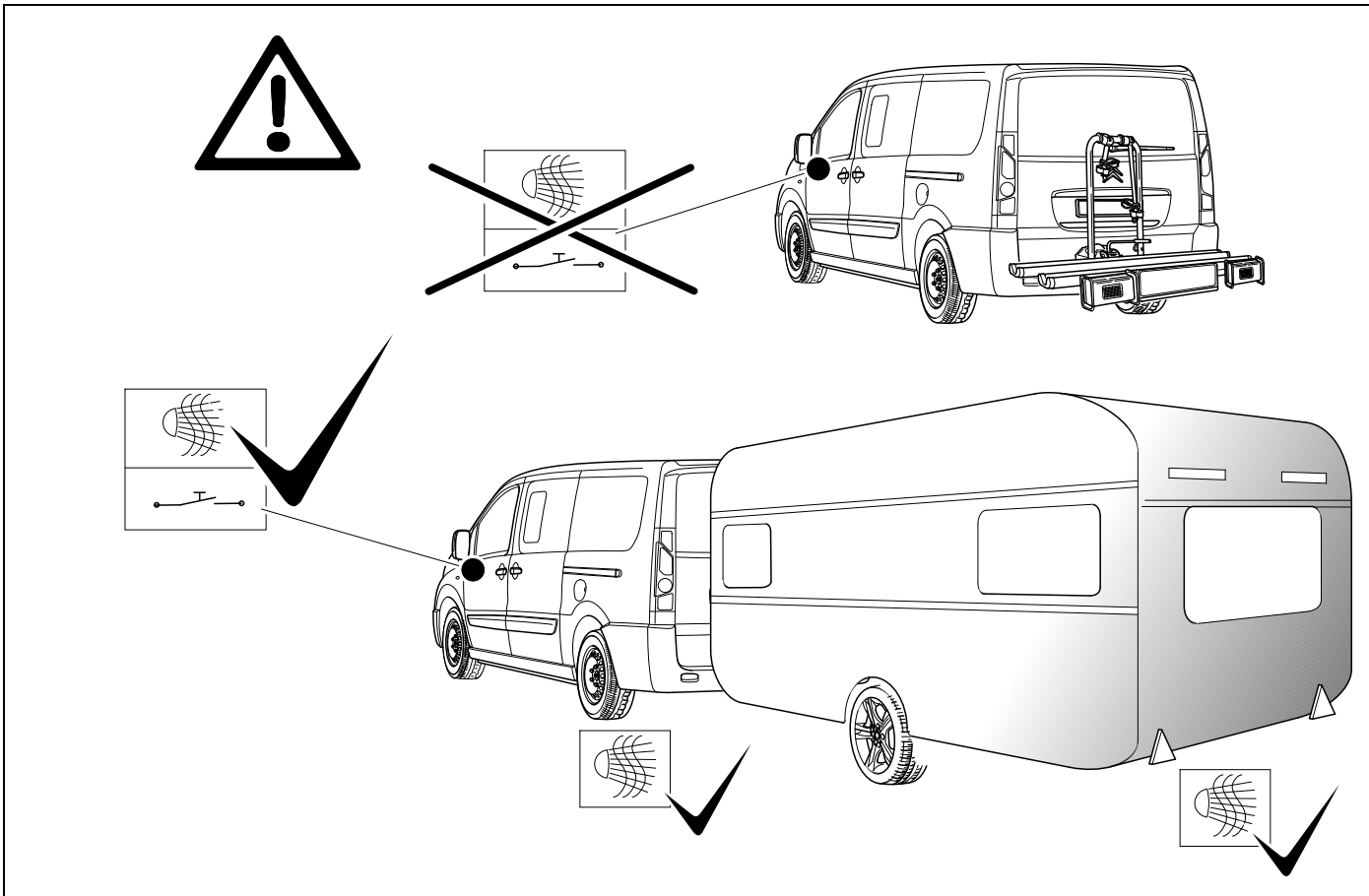

32

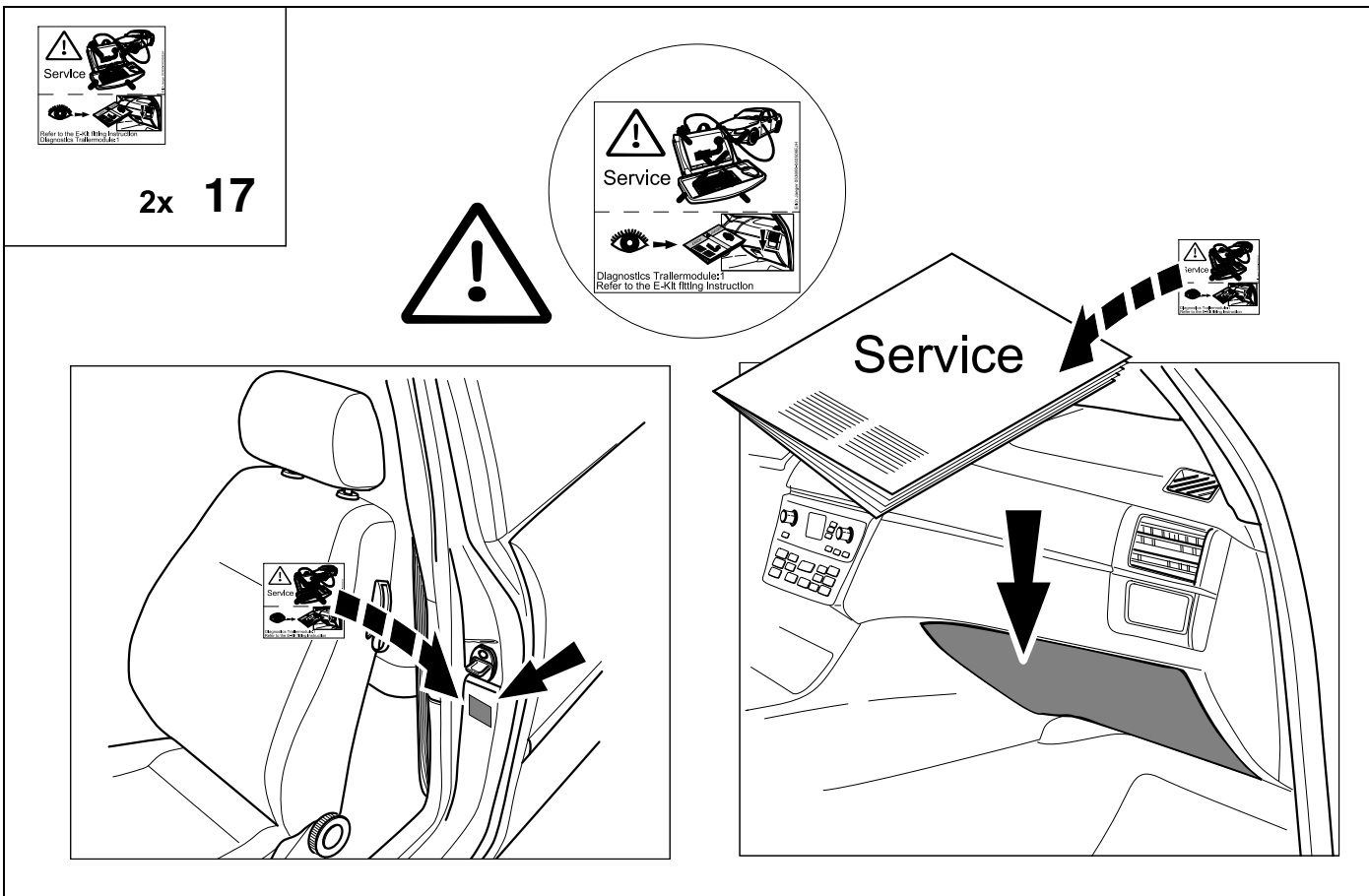

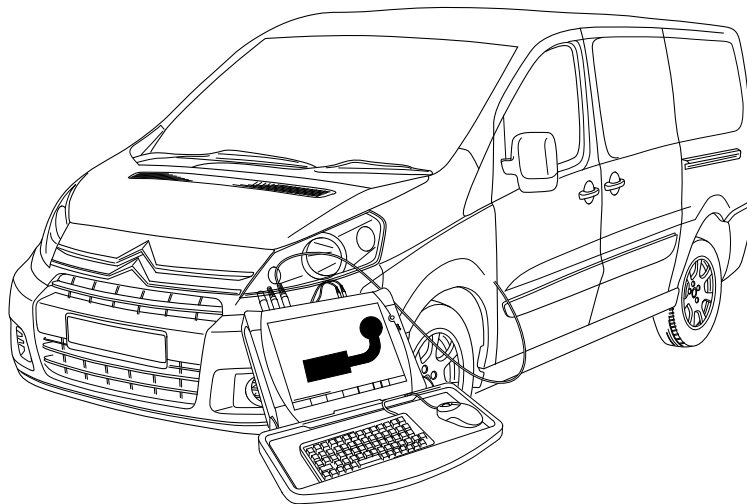

D CITROËN	GB CITROËN	F CITROËN
<p>Die Aktivierung der Anhänger-Blinküberwachung und die Abschaltung der Fahrzeug seitigen Einparkhilfe muss mit Hilfe des CITROËN Proxia- Testers wie folgt durchgeführt werden:</p> <ul style="list-style-type: none"> - Fernladung/Ferncodierung - Installation/ Deinstallation - Auswahl des Fahrzeugtyps - Schalteinheit Anhänger (BSR) - Installation einer Ausstattung <p>PEUGEOT</p> <p>Die Aktivierung der Anhänger-Blinküberwachung und die Abschaltung der Fahrzeug seitigen Einparkhilfe muss mit Hilfe des DIAGBOX-Testers wie folgt durchgeführt werden:</p> <ul style="list-style-type: none"> - Fahrzeug auswählen - Auslieferung - Ausstattungen - Schalteinheit Anhänger (BSR) - Installation einer Ausstattung <p>FIAT</p> <p>Die Aktivierung der Anhänger-Blinküberwachung und die Abschaltung der Fahrzeug seitigen Einparkhilfe muss mit Hilfe des FIAT-EXAMINER- Testers wie folgt durchgeführt werden:</p> <p>Modul Programmierung</p> <ul style="list-style-type: none"> - Test der Steuergeräte - Auswahl des Fahrzeuges - Gruppe <i>SICHERHEIT</i> - Anlage <i>BODY COMPUTER</i> - Aktive Diagnose - Konfiguration - Manuelle Konfiguration des Systems - Weiter bis Untergruppe <i>AUSFÜHRUNG</i> - Anhänger-Steuergerät auf Vorhanden stellen 	<p>The activation of the trailer indicator monitoring and cutoff of the vehicle's PDC must be carried out with the aid of the CITROËN Proxia-Tester as follows:</p> <ul style="list-style-type: none"> - remote loading / remote coding - installation / de-installation - selection vehicle type - trailer control unit (BSR) - installation of equipment <p>PEUGEOT</p> <p>The activation of the trailer indicator monitoring and cutoff of the vehicle's PDC must be carried out with the aid of the DIAGBOX tester as follows:</p> <ul style="list-style-type: none"> - choose vehicle - delivery - equipment - trailer control unit (BSR) - installation of equipment <p>FIAT</p> <p>The activation of the trailer indicator monitoring and cutoff of the vehicle's PDC must be carried out with the aid of the FIAT-EXAMINER- Tester as follows:</p> <p>Module coding</p> <ul style="list-style-type: none"> - Test the controllers - Select the type of vehicle - Group <i>SAFETY</i> - System <i>BODY COMPUTER</i> - Active diagnosis - Configuration - Manual configuration of the system - Continue to subgroup <i>EXECUTION</i> - Set trailer controller to present 	<p>L'activation de la surveillance du clignotant de remorque et la désactivation de l'aide au stationnement côté véhicule doivent être effectuées comme suit à l'aide du testeur Proxia CITROËN:</p> <ul style="list-style-type: none"> - chargement à distance / codification à distance - installation / deinstallation - selection de type de véhicule - partie commutation - remorque (BSR) - installation d'équipement <p>PEUGEOT</p> <p>L'activation de la surveillance du clignotant de remorque et la désactivation de l'aide au stationnement côté véhicule doivent être effectuées comme suit à l'aide du testeur DIAGBOX:</p> <ul style="list-style-type: none"> - choisir des véhicules - livraison - équipements - partie commutation - remorque (BSR) - installation d'un équipement <p>FIAT</p> <p>L'activation de la surveillance du clignotant de remorque et la désactivation de l'aide au stationnement côté véhicule doivent être effectuées comme suit à l'aide du testeur FIAT-EXAMINER:</p> <p>Programmation du module</p> <ul style="list-style-type: none"> - Test des appareils de commande - Sélection du véhicule - Groupe <i>SECURITE</i> - Dispositif <i>BODY COMPUTER</i> - Diagnostic actif - Configuration - Configuration manuelle du système - Continuer jusqu'au sous-groupe <i>EXECUTION</i> - Positionner le poste de commande de remorque sur Disponible

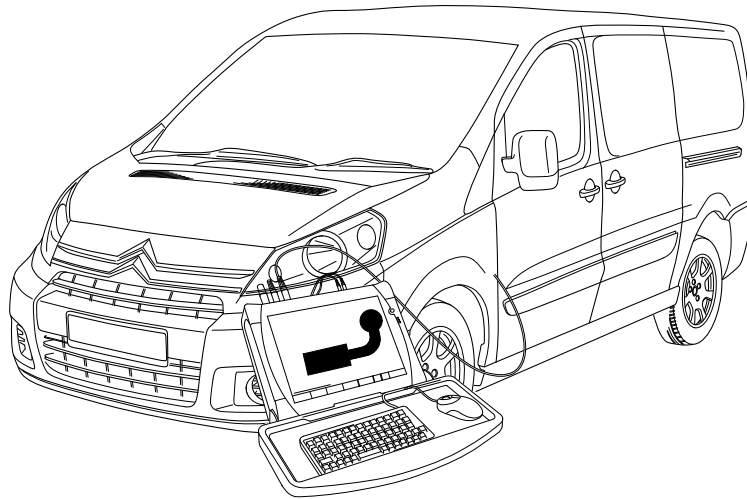

CITROËN

I

L'attivazione del controllo frecce del rimorchio e il disinserimento dell'ausilio parcheggio del veicolo devono essere effettuati come segue mediante il tester Proxia CITROËN:

- Telecarica / telecodifica
- Installazione / deinstallazione
- Scelta tipo veicolo
- Centralina rimorchio (BSR)
- Installazione del equipaggiamento

PEUGEOT

L'attivazione del controllo frecce del rimorchio e il disinserimento dell'ausilio parcheggio del veicolo devono essere effettuati come segue mediante il tester DIAGBOX:

- Scegliere veicolo
- I tempi di consegna
- Attrezzature
- Centralina rimorchio (BSR)
- L'installazione di apparecchiature

FIAT

L'attivazione del controllo frecce del rimorchio e il disinserimento dell'ausilio parcheggio del veicolo devono essere effettuati come segue mediante il tester FIAT-EXAMINER:

Programmazione modulo

- Test delle centraline
- Scelta del veicolo
- Gruppo *SICUREZZA*
- Impianto *BODY COMPUTER*
- Diagnosi attiva
- Configurazione
- Configurazione manuale del sistema
- Continua fino al sottogruppo *ESECUZIONE*
- Impostare la centralina rimorchio su presente

CITROËN

E

La activación del control de los intermitentes del remolque y de la desactivación del sistema de ayuda al aparcamiento del vehículo deberá llevarse a cabo con ayuda del comprobador Proxia de CITROËN de la siguiente manera:

- carga a distancia / codificación por mando a distancia
- instalación / deinstalación
- selección del tipo del vehículo
- unidad de conmutación - remolque (BSR)
- Instalación del equipamiento

PEUGEOT

La activación del control de los intermitentes del remolque y de la desactivación del sistema de ayuda al aparcamiento del vehículo deberá llevarse a cabo con ayuda del comprobador DIAGBOX:

- elegir vehículo
- entrega
- equipo
- unidad de conmutación - remolque (BSR)
- instalación de equipos i

FIAT

La activación del control de los intermitentes del remolque y de la desactivación del sistema de ayuda al aparcamiento del vehículo deberá llevarse a cabo con ayuda del comprobador FIAT-EXAMINER de la siguiente manera:

Programación del modulo

- Comprobación de los reguladores
- Selección del vehículo
- Grupo *SEGURIDAD*
- Instalación *BODY COMPUTER*
- Diagnóstico activo
- Configuración
- Configuración manual del sistema
- Seguir hasta el subgrupo *EJECUCIÓN*
- Indicar que el regulador del remolque está presente

CITROËN

NL

De activering van de aanhangwagen Indicator monitoring en uitschakelen Voertuig kant parkeerhulp moet gebruiken CITROËN Proxia tester worden als volgt uitgevoerd:

- Afstandslading/Afstandscodering
- Installatie/ Desinstallatie
- Keuze van het voertuigtype
- Schakelunit aanhanger (BSR)
- Installatie van een uitvoering

PEUGEOT

De activering van de aanhangwagen Indicator monitoring en uitschakelen Voertuig kant parkeerhulp moet gebruiken DIAGBOX tester worden als volgt uitgevoerd:

- Kies het voertuig
- Levering
- Apparatuur
- Schakelunit aanhanger (BSR)
- Installatie van apparatuur

FIAT

De activering van de aanhangwagen Indicator monitoring en uitschakelen Voertuig kant parkeerhulp moet gebruiken FIAT-EXAMINER-tester worden als volgt uitgevoerd:

Moduleprogramming

- Test van de besturingsapparaten
- Keuze van het voertuig
- Groep *VEILIGHEID*
- Bijlage *BODY COMPUTER*
- Actieve diagnose
- Configuratie
- Handmatige configuratie van het systeem
- Verder naar subgroep *UITVOERING*
- Besturingsapparaat van aanhangwagen op Aanwezig zetten

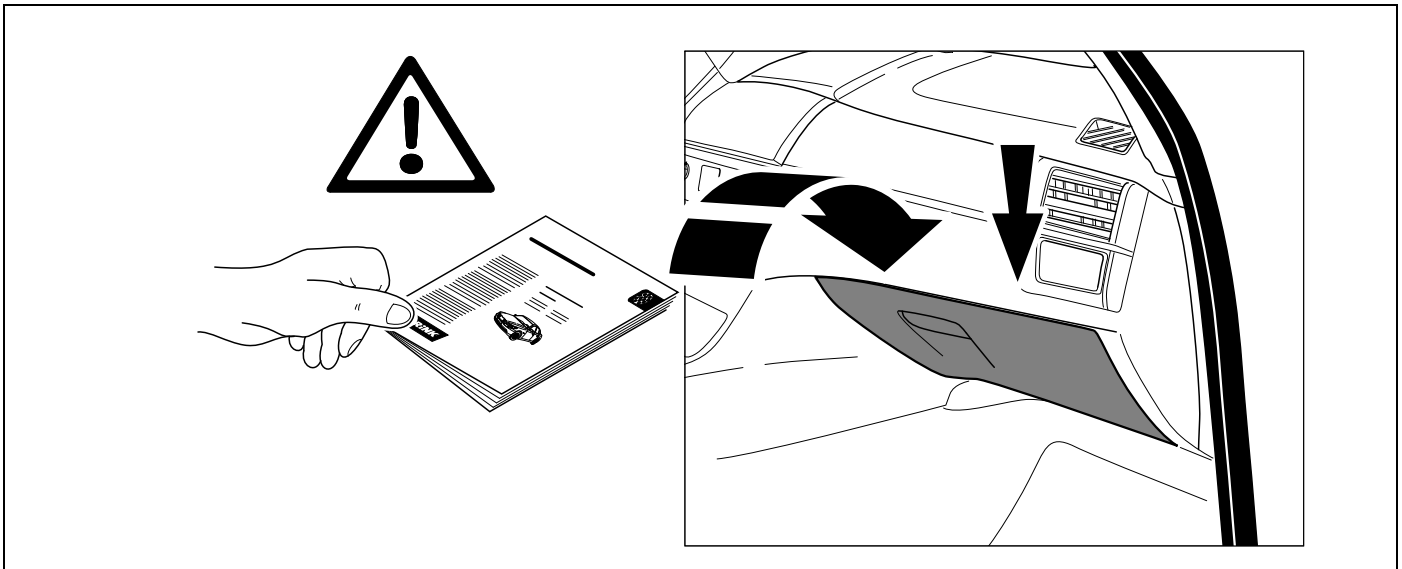

- | | |
|--|--|
| <p>(D) Änderungen bezüglich Konstruktion, Ausstattung Farbe sowie Irrtum vorbehalten.
Angaben und Abbildungen unverbindlich</p> | <p>(PL) Zastrzega się prawo do zmian dot. konstrukcji, wykończenia, kolorystyki oraz pomylek.
Dane i ilustracje niewiążące.</p> |
| <p>(GB) Subject to change in terms of construction, equipment and colour, and may contain errors.
The information and illustrations are non-binding.</p> | <p>(TR) Tasarım, donanım ve renk bakımından değişiklik yapma hakkı ve hata ve eksiklik mahfuzdur. Veriler ve resimler bağlayıcı değildir.</p> |
| <p>(F) Sous réserve de modifications de la construction, de l'équipement, de la couleur et sous réserve d'erreurs. Les indications et les illustrations sont sans engagement.</p> | <p>(H) A szerkezet, a kivitelt és a szín változtatása, valamint a változások joga fenntartva.
Az adatok és az ábrák nem kötelező érvényűek.</p> |
| <p>(NL) Wijzigingen met betrekking tot constructie, uitvoering en kleur evenals vergissingen voorbehouden. Gegevens en afbeeldingen niet bindend.</p> | <p>(HR) Pravo promjena u svezi konstrukcije, opreme, boje kao i zabune oridžavamo.
Podaci i ilustracije su neobavezne.</p> |
| <p>(DK) Ændringer med hensyn til konstruktion, udstyr, farver samt fejl forbeholdes.
Oplysninger og illustrationer er uforpligtende.</p> | <p>(BUL) Запазени права по отношение на конструкцията, обзавеждането, цвета и грешки.
Данните и изображенията не са обвързващи.</p> |
| <p>(N) Endringer angående konstruksjon, utstyr, farge og feiltagelse forbeholdes.
Opplysninger og illustrasjoner uforbindtlig.</p> | <p>(RO) Ne rezervăm dreptul unor modificări ale construcției, dotării, culorii și dreptul la erori
Datele indicate și imaginile sunt orientative.</p> |
| <p>(S) Med reservation för ändringar vad det gäller konstruktion, utrustning, färg samt för misstag. Uppgifterna och bilderna är inte bindande.</p> | <p>(RU) Права на внесение изменений относительно конструкции, оснащения, окраски, а также на ошибки сохраняются. Данные и иллюстрации имеют примерный характер.</p> |
| <p>(FIN) Pidätämme oikeuden rakennetta, varustusta, väriä koskeviin sekä erehdyksestä johtuviin muutoksiin. Tiedot ja kuvat eivät ole sitovia.</p> | <p>(LT) Pasiliekaama konstrukcijos, įrangos bei reikmenų, spalvos pakeitimų ir klaidų teisė.
Duomenys ir iliustracijos neįpareigojantys.</p> |
| <p>(I) Con riserva di modifiche relative a progettazione, dotazione, colore ed errori.
Le indicazioni e figure sono fornite senza impegno.</p> | <p>(LV) Tiek paturētas tiesības uz konstrukcijas, iekārtu, krāsu izmaiņām, kā arī kļūdīšanās.
Dati un attēli bez saistībām.</p> |
| <p>(E) Reservadas las modificaciones respecto a diseño, equipamiento, color, así como error. Indicaciones y figuras sin compromiso.</p> | <p>(EST) Konstruktsiooni, varustuse ja võevi osas muudatused ning eksimine lubatud.
Andmed ja joonised on mittesiduvad.</p> |
| <p>(P) Reservamos o direito de alterações relativamente ao desenho, equipamento, cor, bem como de erro. Os dados e as gravuras não implicam compromisso da nossa parte.</p> | <p>(SLO) Zadržana pravica do sprememb glede konstrukcije, opreme, barve ter pomote.
Podatki in slike so neobvezne.</p> |
| <p>(GR) Διατηρώνουμε κάθε επιφύλαξη ως προς αλλαγές σε σχέση με κατασκευή, εξοπλισμό, διαρρυθμίση, χρωματισμούς και λάθη παραδρομής.</p> | <p>(SK) Zmeny, ktoré sa týkajú konštrukcie, vybavenia, farby, ako aj omyly sú vyhradené.
Údaje a zobrazenia sú nezáväzné.</p> |
| <p>(CZ) Změny, týkající se konstrukce, vybavení, barvy, jakož i omyly jsou vyhrazeny.
Údaje a vyobrazení jsou nezávazné.</p> | |